

FORKARDT

SDVN

*Adjustable
industrial shock absorbers*

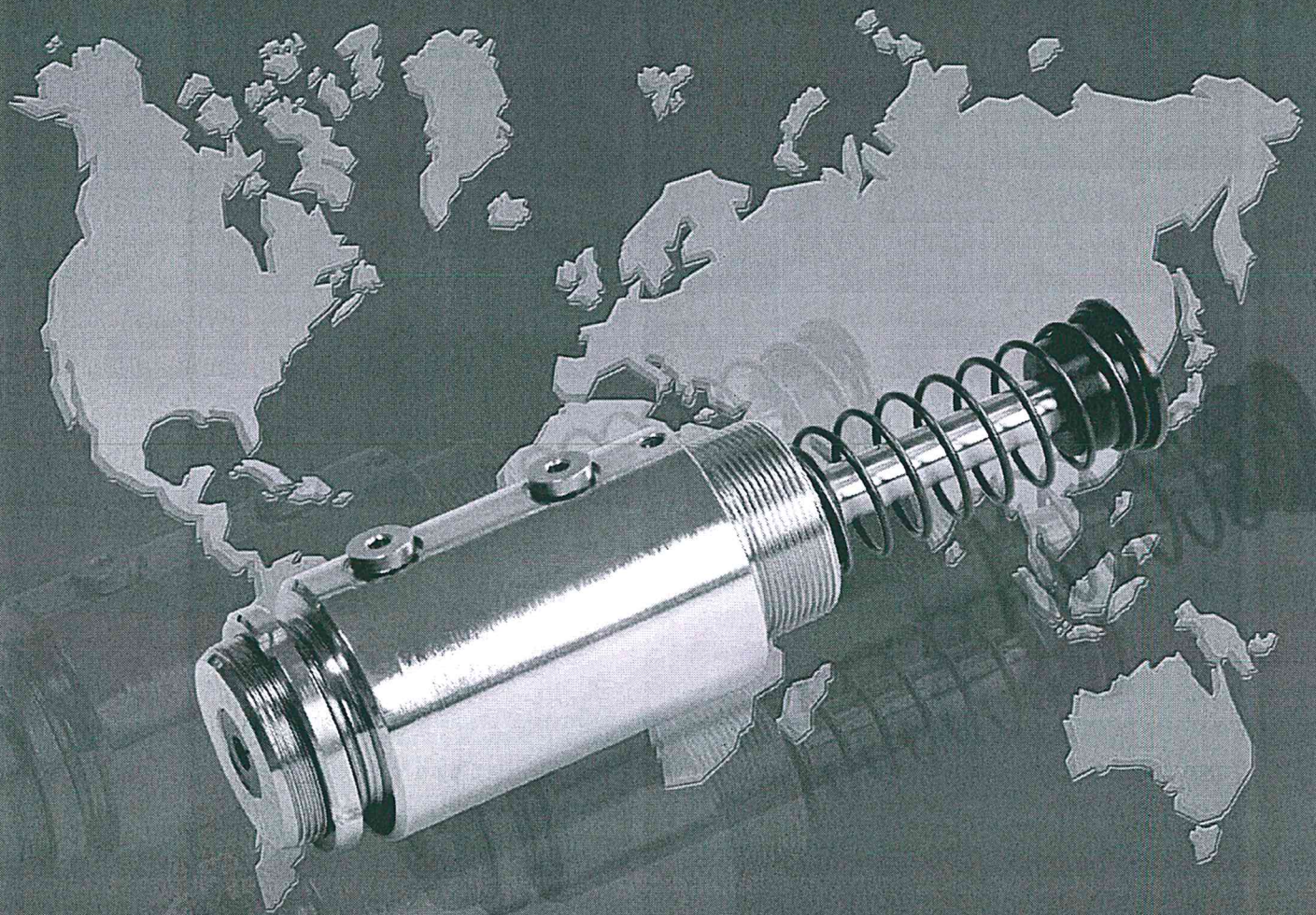

WORKHOLDING SOLUTIONS WORLDWIDE

General information

FORKARDT offers, with its new SDVN series, an extremely comprehensive range of versatile shock absorbers for application within a wide variety situations.

At a glance guide to the most important advantages:

46 various sizes according to requirements

Piston-diameters	6 - 125 mm
Stroke	13 - 500 mm
Working loads	1.5 - 240,000 Nm

DIN / ISO

Piston & piston rod diameter as per DIN 24334
 Seal specifications as per ISO 5597

Adjustable at both ends

From piston diameter of 12 mm:

1. On base
2. On adjusting sleeve

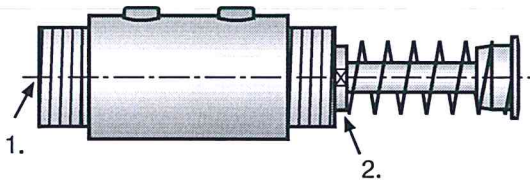

Mounting variations

- (0) • Screw mounting either end
- (1) • Foot mounting
- (2) • Swivel mounting
- (3) • Centre trunnion mounting
- Accessories: Square, rectangular or round flanges (suitable for front or rear). External reservoir, silencer, silencer plate.

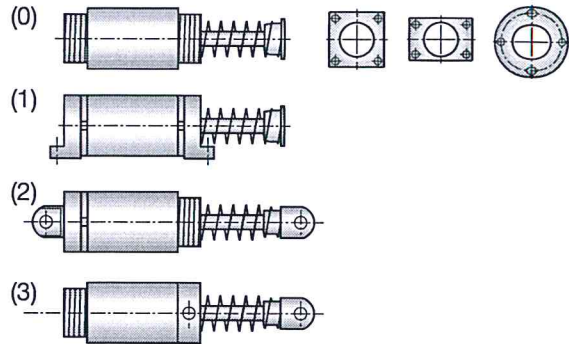

Strengthened piston rod

Above the 32mm diameter piston sizes a larger rod is available for use with an external oil reservoir or limited stroke.

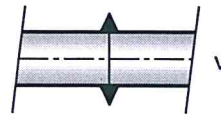

Depending on requirements four different seal systems available

- N = Polyurethane groove seals for normal applications.
- D = Double PTFE-Seal system for extreme conditions.
- Z = Cylinder seals for direct integration with pneumatic cylinders.
- H = Double PTFE-Seal system, together with Viton-O-rings, for high temperatures.

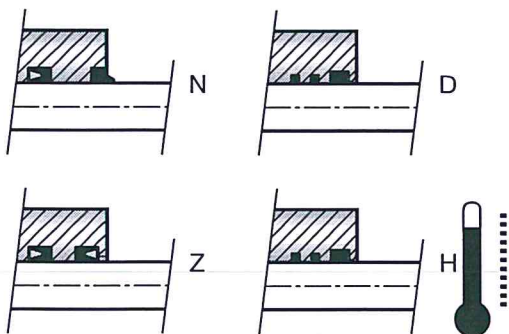

Special versions

- Telescope designs
- Double end working shock absorbers
- Cylinders with integrated shock absorbers
- Shock absorbers with rust free, nickel plated or chromed external parts
- Crane shock absorbers
- Chair lift shock absorbers
- Pre-set or self-adjusting dampers
- Mid-stroke variants
- Special installation models

The kinetic energy

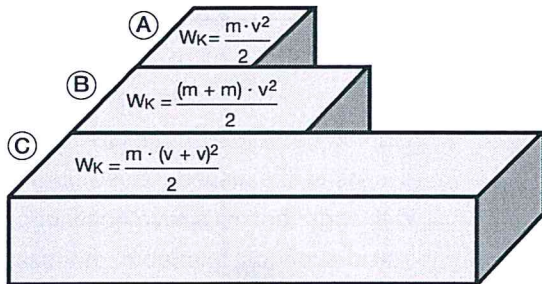

- (A) Kinetic energy
- (B) Double mass = Double energy
- (C) Double speed = Quadrupled energy

The ever increasing growth of automation in all industries demands increased speeds of transport and movement. This results in higher velocity and kinetic energies, which, in proportion, quadruple in relation to this increase.

High movement energy generates

- Damage
- Disturbance
- Production scrap
- Repairs
- Noise

- all of which lead to additional costs!

Costs which arise from the energy of unrestricted motion can be contained.

FORKARDT- Industrial shock absorbers absorb the motion energy. They stop movements softly and reliably.

The additional times needed for this controlled deceleration remain minimal and can be calculated precisely.

Adjustable shock absorbers - why?

No two shock loads are the same. Indeed, it is often not even possible to calculate precisely the actual loads involved.

Pre-set or the so called self-adjusting dampers are often overburdened, because they are designed to function over a limited range. It is often necessary to undertake laborious trials before an acceptable mode of operation can be established, this can be costly.

Therefore, for the multitude of industrial applications the stepless adjustable designs are preferable. In a few seconds the optimum performance can be achieved. Variable loads can be accommodated with ease. As such, time consuming and costly trials can be eliminated.

Therefore:

Don't deal with uncertainty - select a stepless adjustable shock absorber from FORKARDT first time.

Areas of application:

FORKARDT GEFITEC - Industrial Shock Absorbers		
for	to facilitate	for use on
arresting		
workpieces	automation	handling equipment
strips	machining	industrial robots
plates	forming	linear handling units
slabs	loading	rotary handling units
bars	unloading	machine tools
tubes	gripping	plastics processing machines
springs	lifting	textile machines
levers	lowering	packing machines
covers	swivelling	paper making machines
flaps	positioning	welding plants
doors	conveying	mechanisms
gates	closing	transfer equipment
windows	sorting	conveyors and elevators
frames	stacking	manipulators
guards	bundling	wood working machines
gate valves	indexing	pallet conveyors
sildes	handling	
carrriages	machine linking	
cylinders	feeding	

How does a FORKARDT industrial shock absorber work?

What happens, when...

...the piston rod ① is pushed in?

The piston ② presses the oil medium within the cylinder bore ③ through a series of nozzles ④. Progressively, nozzles are closed by the advancing piston, and the displaced oil is then accumulated within the sleeve ⑤.

...the piston rod is pushed out?

Normally this is performed by the spring ⑥. The oil flows back into the cylinder through the non-return valve ⑦.

...the shock absorber is adjusted?

Adjustment is effected according to requirements by either tightening or loosening the adjusters ⑩ and ⑪. This respectively adjusts either the cylinder sleeve ⑫ or the regulating sleeve ⑬. The cross sectional areas of the nozzles are continually changing and in practice this provides harder or softer damping. The adjusters can then be locked with the grub screws ⑭.

FORKARDT - Industrial shock absorbers offer:

- Linear deceleration
- Minimal braking force
- Sensitive and stepless adjustment
- High performance
- Good safety reserves at maximum performance
- Reliability
- Simple servicing
- Metric dimensions
- Variable adaptability with modular programme
- Adjustable from either end
- Seal systems according to application requirements

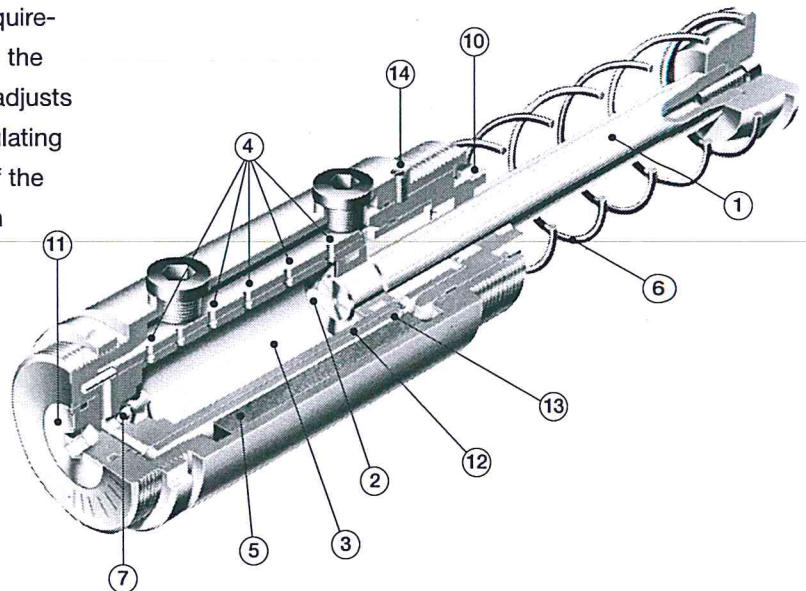

FORKARDT industrial shock absorbers in comparison

to alternative methods

Throughout industry a multitude of damping elements are used with various effects and with varying degrees of effectiveness. High output machines however require an equally high degree of quality damping elements.

It is not acceptable to compromise your solutions. FORKARDT products deliver a wide variety of damping systems for an even wider variety of applications.

S H O C K A B S O R B E R S

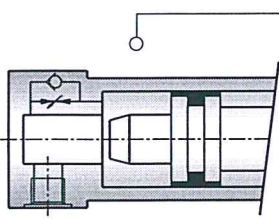

1. Hydraulic end cushioning

The oil flows through an adjustable nozzle. The abrupt closure of this flow area results in a high pressure (force) at the start of the damping stroke. The greater part of the energy is then absorbed after a few mm of piston stroke. The cylinder force then pushes the piston to its end position.

Force distance-diagram

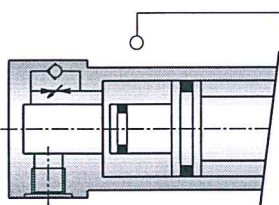
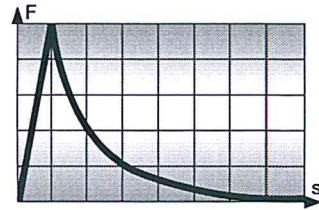

2. Pneumatic end cushioning

Air is compressible. Consequently the damping function is completed only at the end of cushion stroke. The air has been heavily compressed and is used as an energy store. The mass in motion springs back from this effect. Peak pressures of 50-60 bar are not unusual. Pneumatic cylinders are therefore often more bulky in an effort to achieve an adequate cushioning effect.

Force distance-diagram

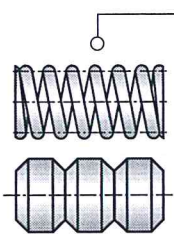
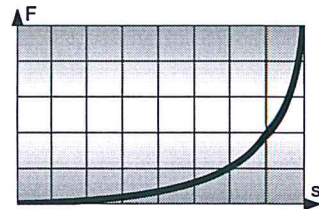

3. Elastic mediums

Spring and rubber dampers provide in principle an elastic damping effect. Whereby the energy is momentarily absorbed and then released. Elastic mediums are normally only recommended for secondary applications.

Force distance-diagram

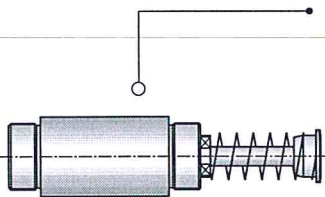
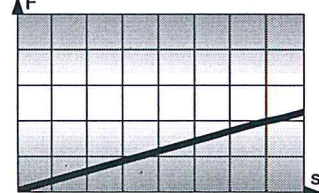

4. FORKARDT GEFITEC industrial shock absorbers

The decelerating forces are low and remain constant throughout the entire stroke. FORKARDT industrial shock absorbers generate less power during function than alternative techniques. The energy is absorbed equally over the entire stroke length. This manner of converting kinetic energy into heat energy approaches the theoretical optimum.

Force distance-diagram

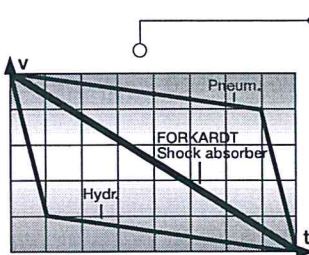
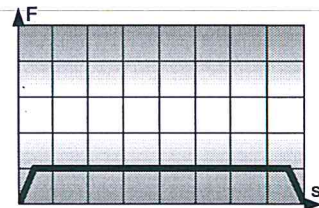

Force distance diagram (all damping elements)

A direct comparison indicates at once the significant advantages of FORKARDT industrial shock absorbers.

- Low and constant deceleration forces throughout the entire stroke (force distance diagram)
- Constant speed of arrest until static (speed time diagram)

Resulting in:

- Greater productivity
- Simple design
- Less noise
- Better motion arrest
- Energy effective
- Increased economy

Speed time - diagram

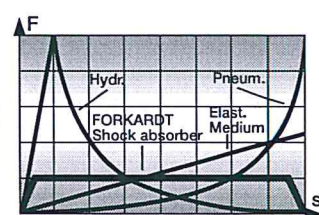

Performance data

Type SDVN	piston ø mm	stroke mm	energy consumption ratings		per hour (AT) ④	max. braking load kg	return force		allowable side force	weight basic vers. approx. kg
			per stroke ①	per hour (IT) ③			Min. N	Max. N		
6 - 13	6	13	14	36	-	70	9	15	3°	0.09
8 - 13	8	13	25	45	-	125	9	21	4°	0.15
8 - 25		25	50	58	-	250	9	24	3°	0.18
10 - 25	10	25	75	70	-	375	14	26	3°	0.28
10 - 50		50	150	92	-	750	15	27	1,5°	0.40
12 - 25	12	25	125	80	120	625	29	50	4°	0.6
12 - 50		50	250	105	152	1,250	26	56	2°	0.75
12 - 75		75	375	130	195	1,875	26	58	1°	0.9
18 - 25	18	25	250	120	180	1,250	56	76	4°	1.1
18 - 50		50	500	150	225	2,500	36	76	3°	1.3
18 - 75		75	750	180	270	3,750	38	76	2°	1.6
18 - 100		100	1,000	210	315	5,000	36	76	1°	1.9
25 - 25	25	25	500	165	248	2,500	83	115	5°	2.0
25 - 50		50	1,000	200	300	5,000	50	115	4°	2.2
25 - 75		75	1,500	235	352	7,500	48	106	2°	2.5
25 - 100		100	2,000	270	405	10,000	50	115	1°	2.9
32 - 50	32	50	1,600	250	375	8,000	97	187	5°	3.7
32 - 75		75	2,400	290	435	12,000	123	226	4°	4.1
32 - 100		100	3,200	330	495	16,000	88	226	3°	4.7
32 - 150		150	4,800	370	555	24,000	73	203	2°	5.6
40 - 50	40	50	2,500	350	525	12,500	154	275	5°	6.5
40 - 75		75	3,750	400	600	18,750	184	322	4°	7.0
40 - 100		100	5,000	450	675	25,000	138	322	3°	8.0
40 - 150		150	7,500	550	825	37,500	144	322	2°	9.5
40 - 200		200	10,000	650	975	50,000	138	322	1°	11.0
50 - 50	50	50	4,000	560	840	20,000	250	373	5°	12.0
50 - 75		75	6,000	650	975	30,000	188	373	4°	13.0
50 - 100		100	8,000	740	1,100	40,000	251	469	3°	14.0
50 - 150		150	12,000	920	1,380	60,000	142	469	2°	17.0
50 - 200		200	16,000	1,080	1,620	80,000	251	469	1°	20.0
63 - 75	63	75	9,000	910	1,365	45,000	382	683	4°	24.0
63 - 100		100	12,000	1,000	1,500	60,000	281	683	3°	26.0
63 - 150		150	18,000	1,200	1,800	90,000	280	693	2°	30.0
63 - 200		200	24,000	1,400	2,100	120,000	281	683	1°	34.0
80 - 100	80	100	20,000	1,400	2,100	100,000	546	834	4°	48.0
80 - 150		150	30,000	1,700	2,550	150,000	402	834	3°	51.0
80 - 200		200	40,000	2,000	3,000	200,000	546	834	2°	61.0
80 - 300		300	60,000	2,500	3,750	300,000	402	834	1°	77.0
100 - 125	100	125	37,500	2,100	3,150	187,500	497	1,275	4°	78.0
100 - 250		250	75,000	2,800	4,200	350,000	396	1,296	3°	101.0
100 - 375		375	112,500	3,500	5,250	562,000	367	1,317	2°	124.0
100 - 500		500	150,000	4,200	6,300	750,000	396	1,296	1°	148.0
125 - 125	125	125	60,000	3,000	4,500	300,000	717	2,096	4°	165.0
125 - 250		250	120,000	4,000	6,000	600,000	642	2,427	3°	204.0
125 - 375		375	180,000	5,000	7,500	900,000	607	2,427	2°	243.0
125 - 500		500	240,000	6,000	9,000	1,200,000	642	2,427	1°	285.0

Technical data:

Permissible velocity 0.2 - 5 m/s
 Permissible temperature range 0 - 80°C
 (variations on request)
 Various mountings possible
 Fixed stop should be 1 mm before end of stroke

- ① When used as emergency damper:
+ 40% permissible
- ② With dash reservoir and oil circuit higher values achievable
- ③ Internal reservoir
- ④ External dash reservoir

Special variations by request

All dampers can be steplessly adjusted to the specified load within the permissible consumption rating.
 When using the internal hydraulic reservoir - the damper is immediately operable after mounting.

Oil Specification: H-LP 32 (ISO-VG3)

S H O C K A B S O R B E R S



Dimensions SDVN 6 bis 10

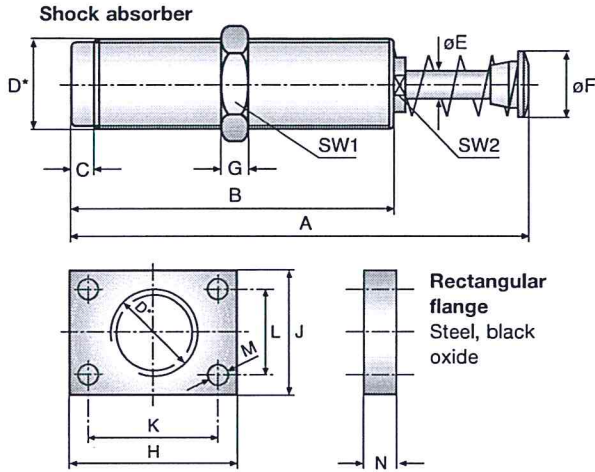

Order example

SDVN 8 - 25 - M 20 x 1.5
 Type _____
 Piston ø _____
 Stroke _____
 Thread _____

Dampers are supplied as standard with internal reservoir and spring return. They are ready for use upon assembly.

Accessory:

Rectangular flange for SDVN 8 - M 20 x 1.5

Type SDVN	A	B	C	D*	* Special thread on request	øE	øF	G	SW1	SW2	Rectangular flange					
											H	J	K	L	øM	N
6 - 13	100	73	7	M 16 x 1.5	-	5	12	5	19	7	35	25	27	17	4.5	10
8 - 13	100	74	7	M 20 x 1.5	M 22 x 1.5	6	15	6	24	10	40	30	32	22	4.5	12
8 - 25	138	97	7	M 20 x 1.5	M 22 x 1.5	6	15	6	24	10	40	30	32	22	4.5	12
10 - 25	143	102	7	M 24 x 1.5	M 25 x 1.5	8	19	8	30	13	50	35	40	25	5.5	12
10 - 50	227	147	7	M 24 x 1.5	M 27 x 1.5, M 27	8	19	8	30	13	50	35	40	25	5.5	12

We reserve the right to change dimensions. Arrange end stop 0.5 - 1 mm before end of stroke. Adjustment by rotating SW2. * Use standard threads. Special threads not suitable for new version.

Additional accessories:

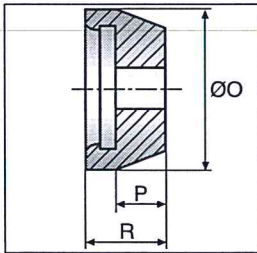

Stop head:
 To push over the ram head
Advantage:
 Noise reduction
Material:
 Nylon

SDVN	strokes	ø O	P	R
6	13	16	6	11
8	13, 25	20	6	11
10	25, 50	24	8	13

Order example:
 Head for SDVN 6

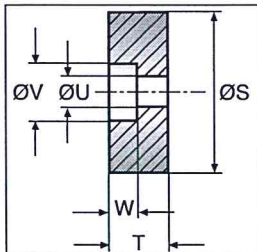

Stop plate:
 To be fitted to item to be braked
Advantage:
 Noise reduction
Material:
 Nylon

SDVN	strokes	ø S	T	ø U	ø V	W
6	13	12	8	3.2	6	3.5
8	13, 25	16	8	3.2	6	3.5
10	25, 50	20	10	4.2	7.5	5

Order example:
 Stop plate for SDVN 10

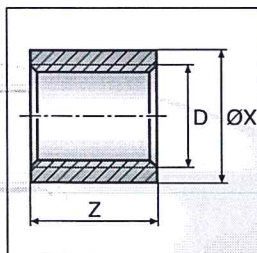

Fixed stop:
 Screwed on thread of damper
Advantage:
 No external stop required
Material:
 Steel, black oxide

SDVN	strokes	D	ø X	Z
6	13	M 16 x 1.5	20	30
8	13, 25	M 20 x 1.5	25	30
10	25, 50	M 24 x 1.5	32	50

Order example:
 Fixed stop for SDVN 8 - M 20 x 1.5

SDVN 12 to 125 Dimension chart

Mounting style 0 / square, rectangular and round flange

Mounting style 0 Screw mounting

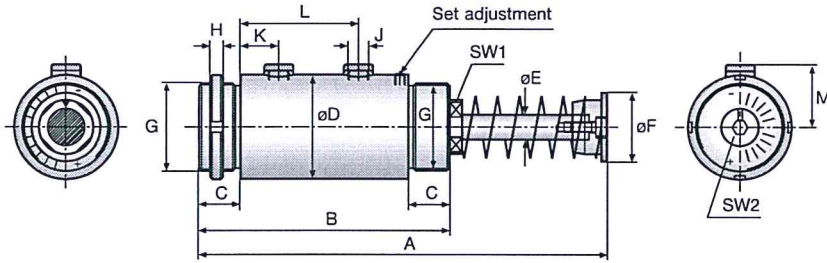

Square flange
(accessory)

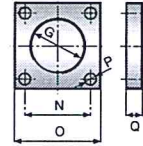

Rectangular flange
(accessory)

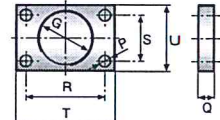

Round flange
(accessory)

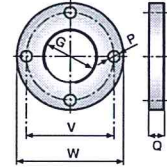

Type SDVN	Mounting style 0 = Screw mounting											Square, rectangular and round flange										
	A	B	C	øD	øE*	øF	G	H	J	K	L	M	N	O	øP	Q	R	S	T	U	V	W
12 - 25	138	83									30											
12 - 50	189	108	16	38	8	25	M32x1.5	6	M5	15	55	22	35	45	6,5	8	42	28	54	40	52	63
12 - 75	255	133									80											
18 - 25	146	95									-											
18 - 50	196	120									56											
18 - 75	246	145	20	52	12	33	M42x1.5	6	R1/8"	18	81	29	50	65	9	12	60	35	75	50	68	83
18 - 100	328	170									106											
25 - 25	155	105									-											
25 - 50	205	130									58											
25 - 75	265	155	22	64	16	40	M52x1.5	8	R1/8"	20	83	35	55	70	9	12	65	45	80	60	80	95
25 - 100	334	180									108											
32 - 50	225	140									59											
32 - 75	280	165									84											
32 - 100	330	190	25	77	20	50	M65x1.5	8	R1/8"	24	109	42	70	90	11	16	80	55	100	75	100	120
32 - 150	455	240									159											
40 - 50	255	165									64											
40 - 75	315	190									89											
40 - 100	365	215	32	95	25	62	M80x2	10	R1/2"	28	114	58	85	110	13	20	100	70	125	95	120	142
40 - 150	485	265									164											
40 - 200	620	315									214											
50 - 50	300	192									73											
50 - 75	350	217									98											
50 - 100	406	242	38	120	32	78	M100x2	12	R1/2"	30	123	70	110	140	17	25	120	90	150	120	150	178
50 - 150	506	292									173											
50 - 200	677	342									223											
63 - 75	380	240									101											
63 - 100	430	265									126											
63 - 150	555	315	41	150	40	95	M125x2	14	R3/4"	43	176	90	130	160	17	25	-	-	-	-	180	208
63 - 200	700	365									226											
80 - 100	488	300									125											
80 - 150	588	350									175											
80 - 200	785	400	48	180	50	112	M150x3	14	R1"	50	225	105	160	200	21	30	-	-	-	-	220	255
80 - 300	985	500									325											
100 - 125	585	375									170											
100 - 250	885	500									295											
100 - 375	1,180	625	55	220	63	138	M180x3	18	R1 1/2"	70	420	125	190	230	26	35	-	-	-	-	265	305
100 - 500	1,530	750									545											
125 - 125	655	420									190											
125 - 250	955	545									315											
125 - 375	1,265	670	65	290	80	178	M240x3	22	R11/2"	70	440	165	250	300	32	40	-	-	-	-	350	400
125 - 500	1,625	795									565											

All models supplied with internal reservoir and Spring ready for assembly.
 *) Models above SDVN 32 with mounting style 2 and 3 are available with heavy duty piston rod. With style 0 and 1 heavy duty piston rod only available with shortened stroke (Stop ring).
 In this instance take the next size up of piston rod diameter.
 Further accessories (stop head, stop plate or silencer) available upon request.

Mounting style 1 Foot mounting

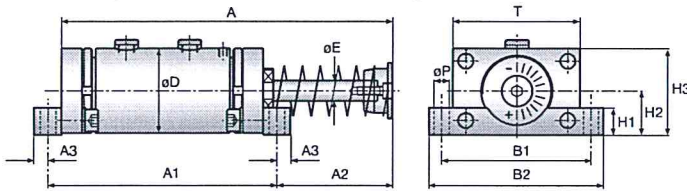

Mounting style 2 Swivel mounting

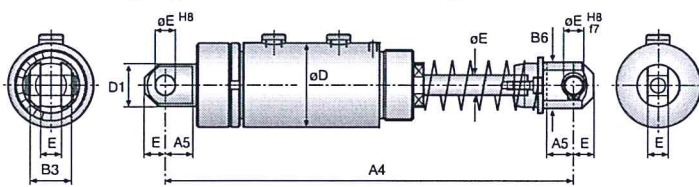

Mounting style 3 Centre trunnion mounting

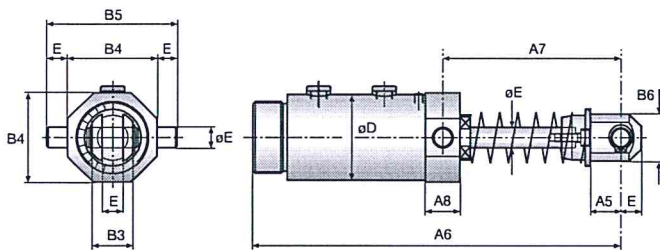

Order example

SDVN 12 - 25 - 0 - 0 - N - V

Type _____
 Piston- ϕ _____
 Stroke _____
 Mounting style _____
 0 = Screw mounting
 1 = Foot mounting
 2 = Swivel mounting
 3 = Centre trunnion mounting
 Function style _____
 0 = Internal reservoir, with spring
 1 = Internal reservoir less spring
 2 = Less internal reservoir with spring
 3 = Less internal reservoir less spring
 Seal style _____
 N = Polyurethane groove seals (Standard)
 D = Double PTFE seal system
 H = Viton seals
 Z = Seals for direct connection on cylinders.
 Heavy duty piston _____

*Above 32 ϕ piston only available with mounting type 2 and 3 or shortened stroke possible.

Type SDVN	size		mounting style 1 - foot mounting										mounting style 2				mounting style 3							
	ϕD	ϕE	A1	A2	A3	B1	B2	H1	H2	H3	ρP	T	A4	A5	B3	B6 _{approx.}	D1	E	A6	A7	A8	B4	B5	
12 - 25			95	49									167					150	75					
12 - 50	38	8	120	75	6	60	72	12	20	40	6.5	54	218	11.5	16	20	8	201	101	16	40	56		
12 - 75			145	116									284					267	142					
18 - 25			111	43									191					164	79					
18 - 50			136	68									241					214	104					
18 - 75	50	12	161	93	8	80	95	16	26	51	9	75	291	18	24	28	25	264	129	20	52	76		
18 - 100			186	150									373					346	186					
25 - 25			125	40									211					179	85					
25 - 50			150	65									261					229	110					
25 - 75	62	16	175	100	10	85	100	20	32	63	9	80	321	24	32	36	36	289	145	22	65	97		
25 - 100			200	144									390					358	189					
32 - 50			164	73									295					255	128					
32 - 75			189	103									350					310	158					
32 - 100	75	20	214	128	12	110	130	24	40	78	11	100	400	30	40	40	40	360	183	26	80	120		
32 - 150			264	203									525					485	258					
40 - 50			195	75									345					293	144					
40 - 75			220	110									405					353	179					
40 - 100	95	25	245	135	15	140	165	30	50	98	13	125	455	38	50	50	50	403	204	32	100	150		
40 - 150			295	205									575					523	274					
40 - 200			345	290									710					658	359					
50 - 50			228	90									410					348	174					
50 - 75			253	115									460					398	199					
50 - 100	120	32	278	146	18	170	200	36	63	123	17	150	516	48	65	72	65	454	230	40	125	189		
50 - 150			328	196									616					554	280					
50 - 200			378	317									787					725	401					
63 - 75			280	120									515					440	216					
63 - 100			305	145									565					490	241					
63 - 150	150	40	355	220	20	180	210	40	80	160	17	160	690	60	80	86	80	615	316	50	160	240		
63 - 200			405	315									835					760	411					
80 - 100			350	163									655					563	281					
80 - 150			400	213									755					663	331					
80 - 200	180	50	450	360	25	220	260	50	100	200	21	200	952	75	100	110	100	860	478	60	190	290		
80 - 300			500	460									1,152					1,060	578					

We reserve the rights to change dimensions
 Arrange end stop 1 mm before end of stroke.
 All models supplied with internal reservoir and spring ready for assembly.
 Refer to mounting style 0 for dimms not given basic style. Various mounting possibilities.

Formular and specimen calculations

Symbols and values applied in the formulae:

W_K = kin. energy/stroke (less propelling force)	Nm/Hub	A = propulsive power ($F \cdot s$)	Nm
W_G = kin. energy/stroke ($W_G = W_K + A$)	Nm/Hub	H_M = Engine holds moment-factor (2.5 normal)	1... 2.5
W_H = kin. energy/ hour (W_G bzw. $W_K \times Z$)	Nm/h	P = power output	kW
m = weight (mass)	kg	Z = strokes per hour	-
v = impact velocity	m/s	J = mass moment of inertia	kgm ²
h = drop height	m	ω = angular velocity	s ⁻¹
s = shock absorber stroke	m	R, r = radius	m
g = gravitational forces	9,81 m/s ²	α = angle	°
a = acceleration / deceleration	m/s ²	D / d = diameter	cm
F = additional propelling force	N	p = system pressure	bar
M_D = drive torque	Nm	F_v = deceleration force	N
		F_s = support force ($F_s = F_v \times 2...3$)	N
		1 N = 0.102 kp - 1 kp	= 9.81 N
		1 Nm = 0.102 mkp - 1 mkp	= 9.81 Nm

General calculations

Calculation for deceleration force

$$F_v = \frac{W_G}{s} \times 1.15 \text{ *) (N)}$$

$$F_s = 2...3 \times F_v$$

Calculation for deceleration time

$$t = \frac{2 \times s}{v} \times 1.15 \text{ *) (s)}$$

*) Correction factors. Apply only by optimum adjustment and conditions.

Calculation for deceleration

$$a = \frac{v^2}{2 \times s} \times 1.15 \text{ *) (m/s}^2\text{)}$$

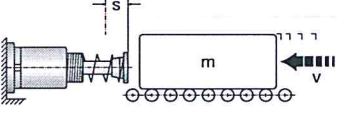
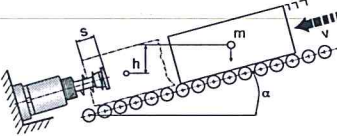
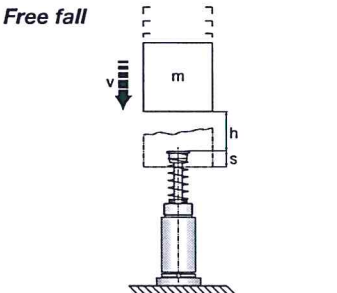
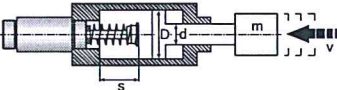
Example	Load	Formulae equations	Calculation equations / options
Mass less drive force 	$m = 200$ kg $v = 2$ m/s $Z = 60$	$W_K = \frac{m \cdot v^2}{2}$ $W_H = W_K \cdot Z$	$W_K = \frac{200 \cdot 2^2}{2} = 400$ Nm/stroke $W_H = 400 \cdot 60 = 24,000$ Nm/h selected: 1 x SDVN 18 - 50 oder: 2 x SDVN 12 - 50
Mass on incline 	$m = 900$ kg $h = 0.25$ m $s = 0.1$ m $\alpha = 15^\circ$ $Z = 30$	$v = \sqrt{2 \cdot g \cdot h}$ $W_K = \frac{m \cdot v^2}{2}$ $A = m \cdot g \cdot s \cdot \sin \alpha$ $W_G = W_K + A$ $W_H = W_G \cdot Z$	$v = \sqrt{2 \cdot 9.81 \cdot 0.25} = 2.21$ m/s $W_K = \frac{900 \cdot 2.21^2}{2} = 2,198$ Nm $A = 900 \cdot 9.81 \cdot 0.1 \cdot 0.259 = 228.5$ Nm $W_G = 2,198 + 228.5 = 2,426.5$ Nm $W_H = 2,426.5 \cdot 30 = 72,795$ Nm/h selected: 1 x SDVN 32 - 100 or: 2 x SDVN 25 - 100
Free fall 	$m = 550$ kg $v = 0.8$ m $s = 0.1$ m $z = 10$	$W_G = m \cdot g \cdot (h + s)$ $v = \sqrt{2 \cdot g \cdot h}$ $W_H = W_G \cdot Z$	$W_G = 550 \cdot 9.81 \cdot (0.8 + 0.1) = 4,856$ Nm $v = \sqrt{2 \cdot 9.81 \cdot 0.8} = 3.96$ m/s $W_H = 4.856 \cdot 10 = 48,560$ Nm/h selected: 1 x SDVN 40 - 100 or: 2 x SDVN 32 - 100 or: 3 x SDVN 25 - 100
End cushioning of cylinders 	$m = 25$ kg $v = 1.8$ m/s $D = 6.3$ cm $d = 2$ cm $p = 6$ bar $s = 0.025$ m $Z = 720$	$W_K = \frac{m \cdot v^2}{2}$ $F = \frac{(D^2 - d^2) \cdot \pi \cdot p \cdot 9.81}{4}$ $A = F \cdot s$ $W_G = W_K + A$ $W_H = W_G \cdot Z$	$W_K = \frac{25 \cdot 1.8^2}{2} = 40.5$ Nm $F = \frac{(6.3^2 - 2^2) \cdot 3.14 \cdot 6 \cdot 9.81}{4} = 1,650$ N $A = 1,650 \cdot 0.025 = 41.25$ Nm $W_G = 40.5 + 41.25 = 81.75$ Nm $W_H = 81.75 \cdot 720 = 58,860$ Nm/h selected: 1 x SDVN 12 - 25

Formular and specimen calculations

Example	Load	Formulae equations	Calculation equations / options
Mass with additional drive force 	m = 280 kg v = 1.6 m/s F = 3,200 N s = 0.05 m Z = 550	$W_G = \frac{m \cdot v^2}{2} + F \cdot s$ $W_H = W_G \cdot Z$	$W_G = \frac{280 \cdot 1.6^2}{2} + 3,200 \cdot 0.05 = 518.4 \text{ Nm}$ $W_H = 518.4 \cdot 550 = 285,120 \text{ Nm/h}$
	required: W_G, W_H	selected: 2 x SDVN 18 - 50 or: 1 x SDVN 25 - 50 <i>with external reservoir</i>	

Mass with motor drive 	m = 2,400 kg v = 1.5 m/s P = 2.5 kW s = 0.1 m H _M = 2.5 Z = Emergency	$W_K = \frac{m \cdot v^2}{2}$ $A = \frac{P \cdot s \cdot 1,000 \cdot H_M}{v^2}$ $W_G = W_K + A$	$W_K = \frac{2,400 \cdot 1.5^2}{2} = 2,700 \text{ Nm}$ $A = \frac{2.5 \cdot 0.1 \cdot 1,000 \cdot 2.5}{1.5} = 417 \text{ Nm}$ $W_G = 2,700 + 417 = 3,117 \text{ Nm/h}$
	required: W_K, A, W_G	selected: 1 x SDVN 32 - 100 or: 2 x SDVN 25 - 100	

Mass with index drive 	m = 800 kg v = 1.2 m/s M _D = 33,600 Nm R = 1.2 m s = 0.05 m Z = 240	$W_K = \frac{m \cdot v^2}{2}$ $A = \frac{M_D}{R} \cdot s$ $W_G = W_K + A$ $W_H = W_G \cdot Z$	$W_K = \frac{800 \cdot 1.2^2}{2} = 576 \text{ Nm}$ $A = \frac{33,600}{1.2} \cdot 0.05 = 1,400 \text{ Nm}$ $W_G = 576 + 1,400 = 1,976 \text{ Nm}$ $W_H = 1,976 \cdot 240 = 474,240 \text{ Nm/h}$
	required: W_K, A, W_G, W_H	selected: 1 x SDVN 50 - 50 or: 2 x SDVN 32 - 50 or: 2 x SDVN 25 - 50 <i>with external reservoir</i>	

Swing mass with additional drive 	m = 230 kg v = 0.8 m/s R = 1.5 m r = 0.75 m F = 6,500 N s = 0.1 m Z = 120	$W_K = \frac{m \cdot v^2}{2}$ $A = \frac{F \cdot r \cdot s}{R}$ $W_G = W_K + A$ $W_H = W_G \cdot Z$	$W_K = \frac{230 \cdot 0.8^2}{2} = 73.6 \text{ Nm}$ $A = \frac{6,500 \cdot 0.75}{1.5} \cdot 0.1 = 325 \text{ Nm}$ $W_G = 73.6 + 325 = 398.6 \text{ Nm}$ $W_H = 398.6 \cdot 120 = 47,832 \text{ Nm/h}$
	required: W_K, A, W_G, W_H	selected: 1 x SDVN 18 - 100 or: 1 x SDVN 25 - 100	

Rotating mass 	J = 500 kgm ² ω = 2 s ⁻¹ M _D = 1,500 Nm R = 0.6 m s = 0.05 m Z = 480	$W_K = \frac{J \cdot \omega^2}{2}$ $A = \frac{M_D}{R} \cdot s$ $W_G = W_K + A$ $W_H = W_G \cdot Z$	$W_K = \frac{500 \cdot 2^2}{2} = 1,000 \text{ Nm}$ $A = \frac{1,500}{0.6} \cdot 0.05 = 125 \text{ Nm}$ $W_G = 1,000 + 125 = 1,125 \text{ Nm}$ $W_H = 1,125 \cdot 480 = 540,000 \text{ Nm/h}$
	required: W_K, A, W_G, W_H	selected: 1 x SDVN 32 - 50 <i>with closed circuit oil</i> 1 x SDVN 40 - 50 <i>with external reservoir</i> 1 x SDVN 50 - 50	

FORKARDT

OUR BRANDS

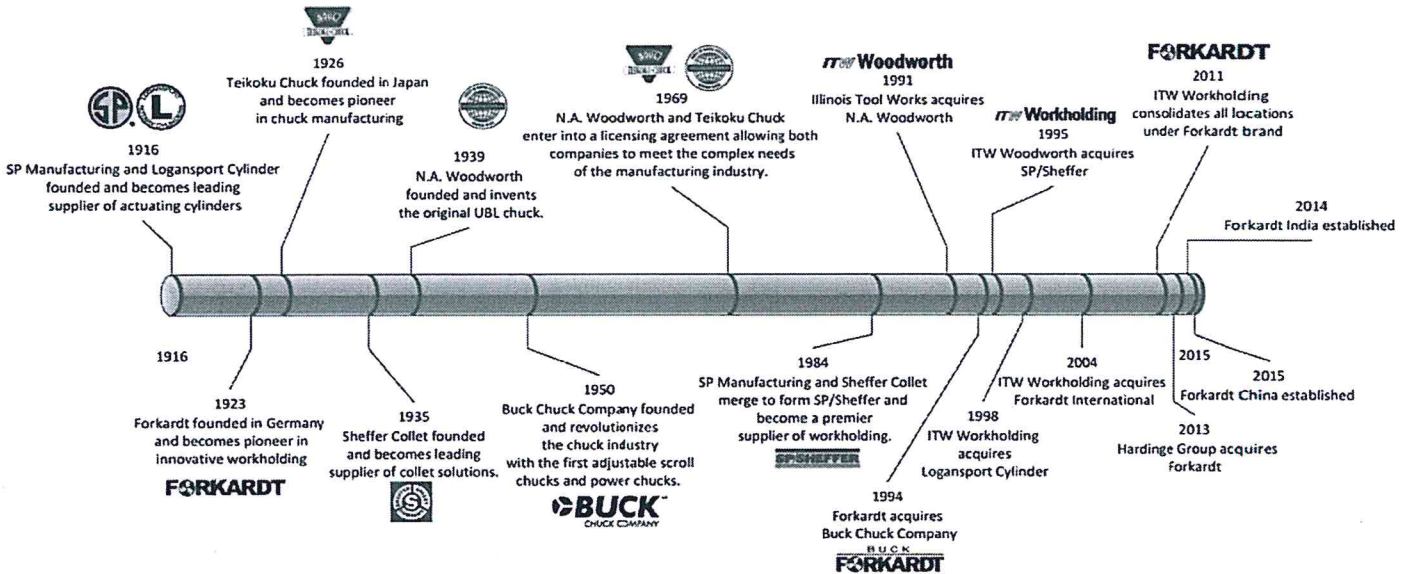

Innovative Technology by **FORKARDT**

L O C A T I O N S W O R L D W I D E

FORKARDT DEUTSCHLAND GMBH
Heinrich-Hertz-Str. 7
D-40699 Erkrath
Phone: (+49) 211 25 06-0
Fax: (+49) 211 25 06-221
E-Mail: info@forkardt.com

FORKARDT FRANCE S.A.R.L.
28 Avenue de Bobigny
F-93135 Noisy le Sec Cédex
Phone: (+33) 1 4183 1240
Fax: (+33) 1 4840 4759
E-Mail: forkardt.france@forkardt.com

FORKARDT INDIA LLP
Plot No. 39 D.No.5-5-35
Ayyanna Ind. Park
IE Prasanthnagar, Kukatpally
Hyderabad - 500 072
India
Phone: (+91) 40 400 20571
Fax: (+91) 40 400 20576
E-Mail: info@forkardtindia.com

FORKARDT USA
2155 Traversefield Drive
Traverse City, MI 49686, USA
Phone: (+1) 800 544-3823
(+1) 231 995-8300
Fax: (+1) 231 995-8361
E-Mail: sales@forkardt.us
Website: www.forkardt.us

FORKARDT CHINA
Precision Machinery (Shanghai) Co Ltd
1F, #45 Building, No. 209 Taigu Road,
Waigaoqiao FTZ CHINA 200131,
CHINA
Phone: (+86) 21 5868 3677
E-Mail: info@forkardt.cn.com
Website: www.forkardt.us

www.forkardt.com

www.forkardt.us