

3 WAYS BALL VALVE THREADED PN 40



ISO 9001 : 2015



PED 2014/68/EU



Certificate 3.1



Size : DN 1/4" to 2"
Ends : Threaded BSP
Min Temperature : - 25°C
Max Temperature : + 180°C
Max Pressure : 40 Bars
Specifications : ISO 5211 mounting pad
PTFE filled with 15% glass fiber seat
Anti blow-out stem

Materials : Stainless steel ASTM A351 CF8M

3 WAYS BALL VALVE THREADED PN 40

SPECIFICATIONS :

- Reduced bore
- Anti blow-out stem
- PTFE filled with 15% glass fiber seat
- Double antistatic device (small ball between stem-body and stem-ball)
- Locking device
- ISO 5211 mounting pad
- Tightness on 3 ways
- L or T port

USE :

- Chemical and pharmaceutical industries, petrochemical industries, hydraulic installation, compressed air
- Min and max Temperature Ts : -25°C to + 180°C
- Max Pressure Ps : 40 bars (see graph)

RANGE :

- Stainless steel with L port **Ref. 780** from DN 1/4" to 2"
- Stainless steel with T port **Ref. 781** from DN 1/4" to 2"

ENDS :

- Threaded BSP female cylindrical ends

PRESSURE / TEMPERATURE GRAPH (STEAM EXCLUDED) :

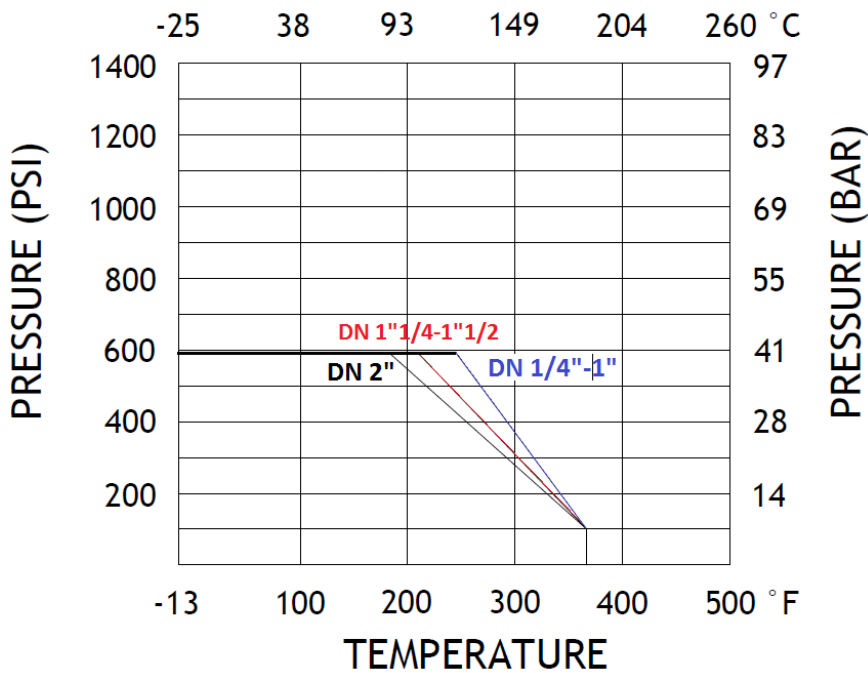

3 WAYS BALL VALVE THREADED PN 40
FLOW COEFFICIENT Kvs (M3/H) :

| Ref. | DN | 1/4" | 3/8" | 1/2" | 3/4" | 1" | 1"1/4" | 1"1/2" | 2" |
|-----------|----------------|------|------|------|------|------|--------|--------|------|
| 780 / 781 | Kvs (M3 / H) | 2.29 | 3.86 | 4.75 | 5.11 | 11.8 | 19.6 | 33.2 | 53.7 |

TORQUE VALUES (in Nm without safety coefficient) :

| DN | 1/4" | 3/8" | 1/2" | 3/4" | 1" | 1"1/4" | 1"1/2" | 2" |
|---------------|------|------|------|------|----|--------|--------|----|
| Torque (Nm) | 8 | 8 | 8 | 9 | 15 | 20 | 30 | 45 |



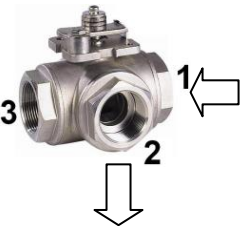
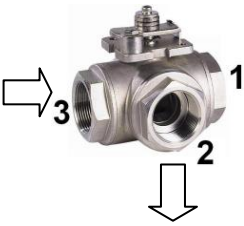
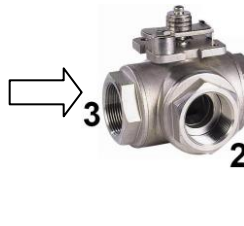
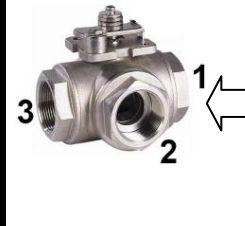
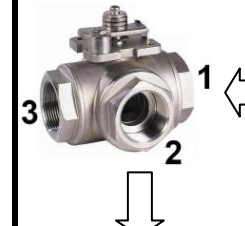
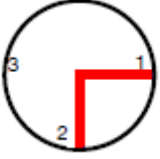
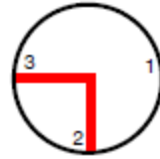
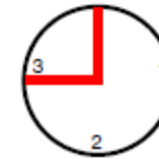
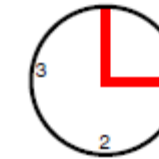
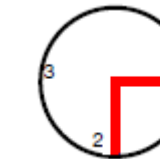

3 WAYS BALL VALVE THREADED PN 40

POSSIBLES POSITIONS :

L Port (only 2 consecutive positions are possibles)

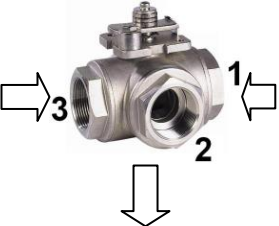
| Position L1 | Position L2 | Position L3 | Position L4 | Position L5 |
|--|--|--|---|--|
|  |  |  |  |  |
|  |  |  |  |  |

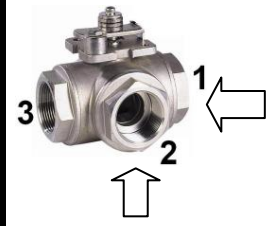
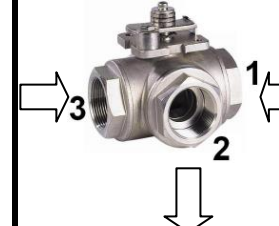
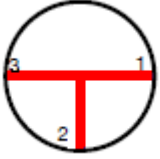
T Port (only 2 consecutive positions are possibles)

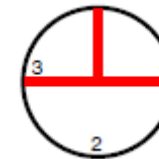
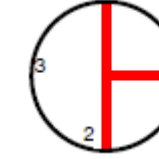
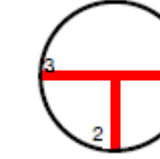
| Position T1 | Position T2 | Position T3 | Position T4 | Position T5 |
|---|---|---|--|---|
|  |  |  |  |  |
|  |  |  |  |  |

3 WAYS BALL VALVE THREADED PN 40

MATERIALS :

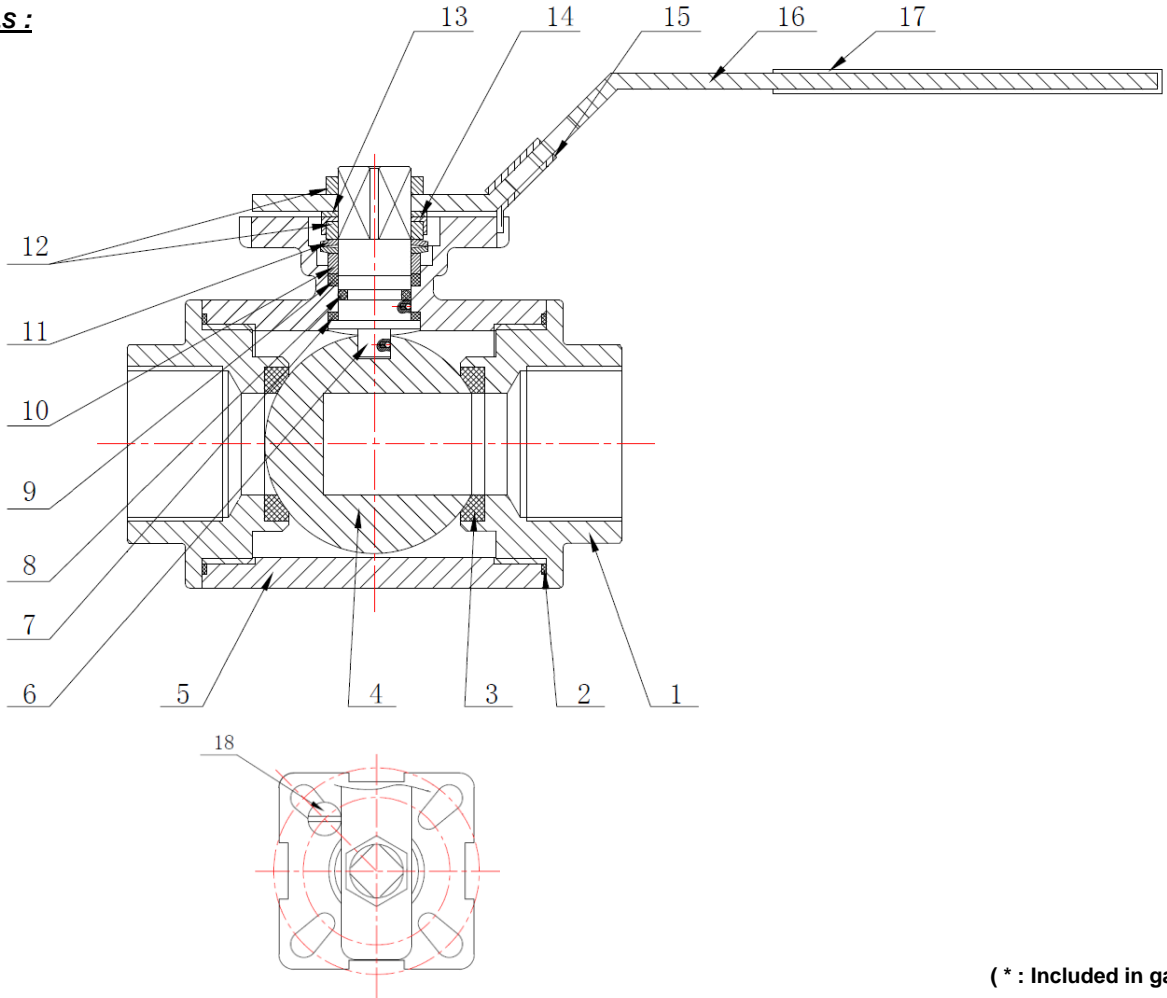

(* : Included in gaskets kit)

| Item | Designation | Materials |
|------|----------------|----------------------------------|
| 1 | Ends | ASTM A351 CF8M |
| 2* | Body gasket | PTFE |
| 3* | Seat | PTFE filled with 15% glass fiber |
| 4 | Ball | AISI 316 |
| 5 | Body | ASTM A351 CF8M |
| 6 | Stem | AISI 316 |
| 7* | Stem gasket | PTFE |
| 8* | O ring | FKM |
| 9* | Packing | PTFE |
| 10 | Gland | AISI 316 |
| 11 | Elastic ring | AISI 301 |
| 12 | Nut | AISI 304 |
| 13 | Washer | AISI 304 |
| 14 | Packing nut | AISI 304 |
| 15 | Locking device | AISI 304 |
| 16 | Handle | AISI 304 |
| 17 | Handle cover | Plastic |
| 18 | Stop pin | AISI 304 |

3 WAYS BALL VALVE THREADED PN 40

SIZE (in mm):

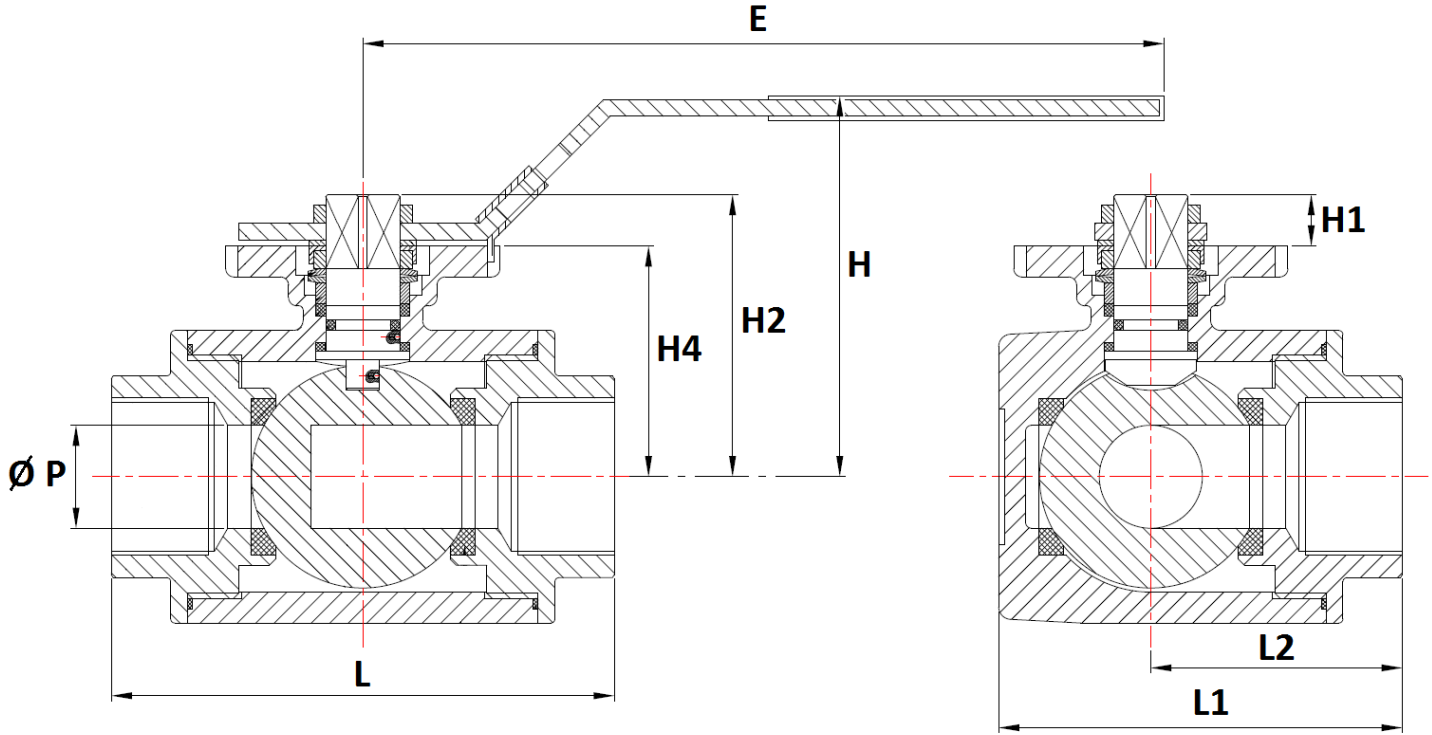

| Ref. | DN | 1/4" | 3/8" | 1/2" | 3/4" | 1" | 1"1/4" | 1"1/2" | 2" |
|-----------|-------------|------|------|------|------|------|--------|--------|------|
| 780 / 781 | Ø P | 9.5 | 11 | 12 | 15 | 20 | 25 | 32 | 40 |
| | L | 75 | 75 | 75 | 85 | 100 | 122 | 131 | 158 |
| | L1 | 57.5 | 57.5 | 57.5 | 65.5 | 79 | 97 | 106.5 | 129 |
| | L2 | 37.5 | 37.5 | 37.5 | 42.5 | 50 | 61 | 65.5 | 79 |
| | E | 130 | 130 | 130 | 161 | 161 | 203 | 203 | 203 |
| | H | 66 | 66 | 66 | 72 | 77 | 92 | 96 | 107 |
| | H1 | 8.5 | 8.5 | 8.5 | 11 | 12 | 13.5 | 13.5 | 13 |
| | H2 | 45.3 | 45.3 | 45.3 | 52 | 58.5 | 69.5 | 73.5 | 83.5 |
| | H4 | 36.8 | 36.8 | 36.8 | 41.2 | 46.5 | 56 | 60 | 70.5 |
| | Weight (Kg) | 0.70 | 0.67 | 0.63 | 0.94 | 1.39 | 2.91 | 3.66 | 6.31 |

3 WAYS BALL VALVE THREADED PN 40

ISO MOUNTING PAD AND STEM SIZE (in mm):

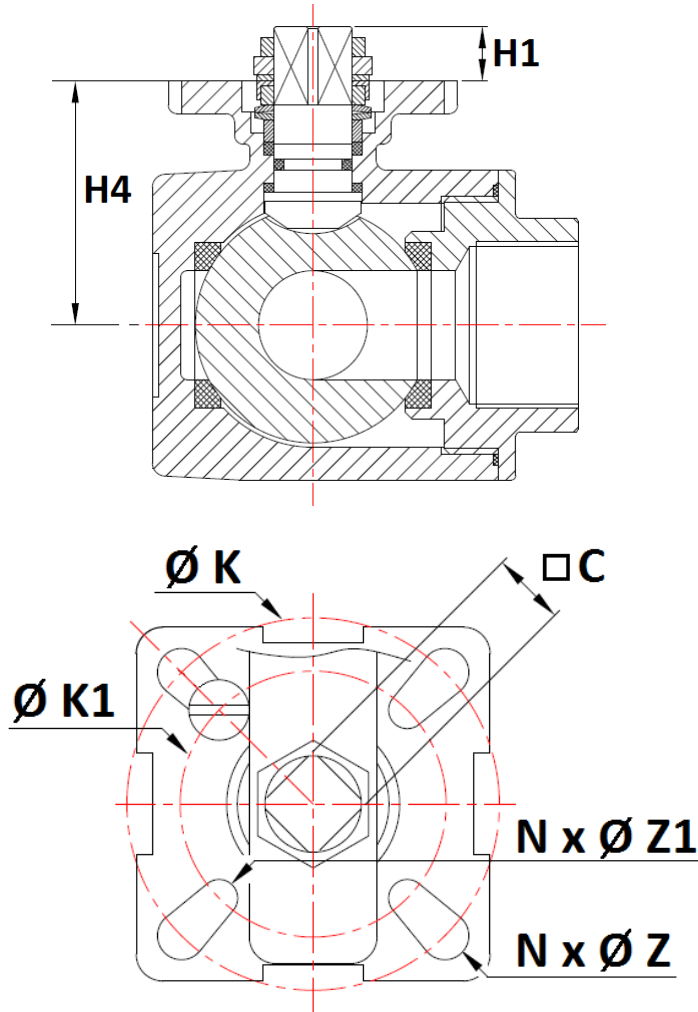

| Ref. | DN | 1/4" | 3/8" | 1/2" | 3/4" | 1" | 1"1/4" | 1"1/2" | 2" |
|-----------|----------|-------|-------|-------|-------|-------|--------|--------|-------|
| 780 / 781 | C | 9 | 9 | 9 | 11 | 11 | 14 | 14 | 14 |
| | H1 | 8.5 | 8.5 | 8.5 | 11 | 12 | 13.5 | 13.5 | 13 |
| | H4 | 36.8 | 36.8 | 36.8 | 41.2 | 46.5 | 56 | 60 | 70.5 |
| | Ø K | 42 | 42 | 42 | 50 | 50 | 70 | 70 | 70 |
| | ISO | F04 | F04 | F04 | F05 | F05 | F07 | F07 | F07 |
| | N x Ø Z | 4 x 6 | 4 x 6 | 4 x 6 | 4 x 7 | 4 x 7 | 4 x 9 | 4 x 9 | 4 x 9 |
| | Ø K1 | 36 | 36 | 36 | 42 | 42 | 50 | 50 | 50 |
| | ISO | F03 | F03 | F03 | F04 | F04 | F05 | F05 | F05 |
| | N x Ø Z1 | 4 x 6 | 4 x 6 | 4 x 6 | 4 x 6 | 4 x 6 | 4 x 7 | 4 x 7 | 4 x 7 |

3 WAYS BALL VALVE THREADED PN 40

STANDARDS :

- Fabrication according to ISO 9001 : 2015
- DIRECTIVE 2014/68/EU : CE N° 0036
Risk Category II Module A2
- Certificate 3.1 on request
- Pressure tests according to API 598, Table 6
- Threaded BSP cylindrical ends according to ISO 7-1 Rp
- ISO 5211 mounting pad
- ATEX Group II Category 2 GD c T2 Zone 1 & 21 Zone 2 & 22 (optional marking)

3 WAYS BALL VALVE THREADED PN 40

INSTALLATION AND MAINTENANCE

BEFORE INSTALLATION :

Pipe-line must be cleaned and free from residual of weldings, rubbish, shaving and every kind of extraneous materials.
Pipe-line must be perfectly aligned and their support properly dimensioned so that there's no external constraint.

Please use the right product according to the services conditions to seal the valve.
Use the right bolt tightening so that the ends won't be damaged.

CLEANING AND TESTS

Keep opened the valves during the cleaning operation so that there are no impurities between the ball and the body.

Tests under pressure must be done with a cleaned pipe-line.

Open partially the valve for tests. Pressure test do not exceed the valve specifications according to API 598.

MAINTENANCE

It's recommended to operate the valve twice (open and close) 1 to 2 times per year.

When intervention on the valve, be sure there's no pressure in the pipe-line, there's no fluid in it, and that it is isolated.
The temperature must be low enough to operate without risks.
If there's a corrosive fluid, inert installation before intervention.

When the valve is under pressure :

If there's a leakage at the packing, tighten it slightly so that the leakage disappears.