

Rotary clamping latches

SPECIFICATION

Types

- Type **RG**: Operation with knurled knob
- Type **VK7**: Operation with square spindle A/F7
- Type **VK8**: Operation with square spindle A/F8
- Type **DK**: Operation with triangular spindle (DK7)
- Type **SK6**: Operation with hexagon A/F6
- Type **VDE**: Operation with double bit

Housing

Zinc die casting
black plastic coated
black, RAL 9005, textured finish

other parts

Steel
zinc plated, blue passivated

Knurled knob (type RG)

Plastic (Polyamide PA)

- Handle black, matt
- Cover cap, light grey matt



INFORMATION

The outstanding feature of the rotary clamping latches GN 116.1 is their wide clamping range of 12 mm, with the 5 keys A1 to A5 covering a clamping range of 4 to 46 mm with broad overlap. This configuration allows large closing strokes within the individual key spacings, e.g. in connection with seals.

With the permissible tightening torque of 2 Nm for the clamping screw, the key generates a closing force of approx. 300 Nm at the key.

TECHNICAL INFORMATION

- List of latch types (see page 1456)
- Plastic characteristics (see page A2)

ACCESSORY

- Socket keys GN 119.2 (see page 1530)

CONSTRUCTION AND ASSEMBLY INSTRUCTIONS

By turning the latch clockwise, the key is first turned by 90° and so moved into the closing position.

When continuing to turn, the thread (M10) will move it in axial direction (max. 12 mm) and will finally clamp the door against the frame.

When opening by turning anti-clockwise, the key will move back and will release the door by a 90° turn.

The pressure spring generates the friction required for the 90° turn. When mounting, the door is fitted with a bore hole as shown in the outline drawing.

The interlock is pushed through the bore hole from the front, the hexagon nut can be pushed over the key from the back. The mounting step is only possible if the key is located axially in the end position and approximately in the middle of the range of rotation.

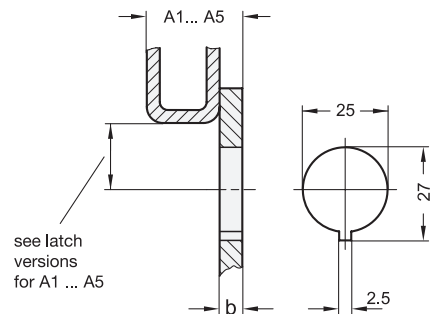

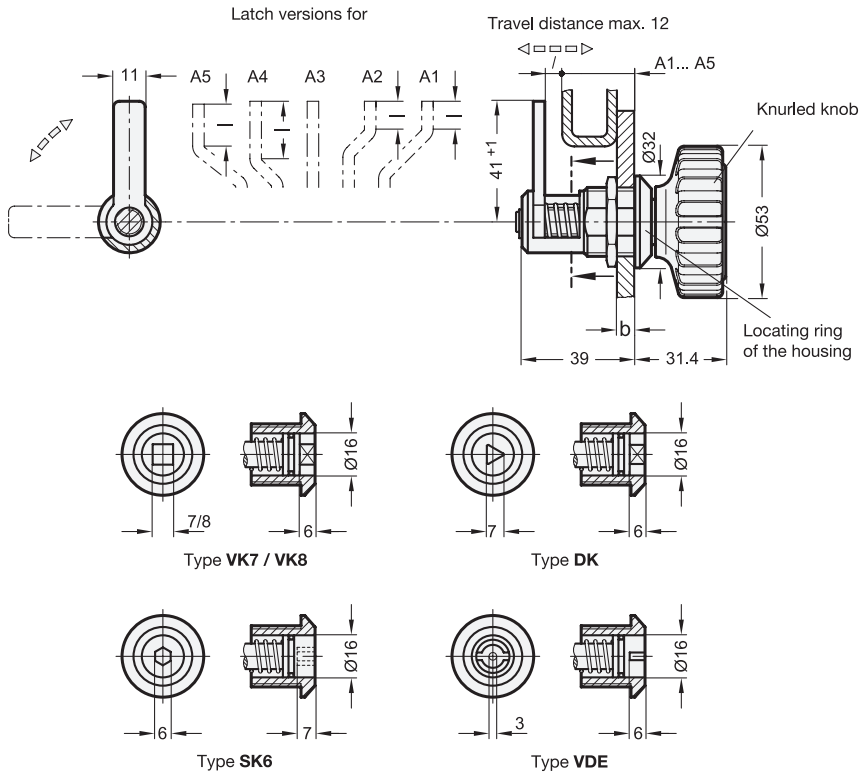

GN 116.1

Description	Clamping range A	Clamping range	b max.	l ≈	△
GN 116.1-DK-A1	A1	4 - 16	6	9.5	100
GN 116.1-DK-A2	A2	11 - 23	10	9.5	103
GN 116.1-DK-A3	A3	19 - 31	12	-	103
GN 116.1-DK-A4	A4	27 - 39	12	20	104
GN 116.1-DK-A5	A5	34 - 46	12	15	105
GN 116.1-RG-A1	A1	4 - 16	6	9.5	140
GN 116.1-RG-A2	A2	11 - 23	10	9.5	140
GN 116.1-RG-A3	A3	19 - 31	12	-	141
GN 116.1-RG-A4	A4	27 - 39	12	20	141
GN 116.1-RG-A5	A5	34 - 46	12	15	143
GN 116.1-SK6-A1	A1	4 - 16	6	9.5	110
GN 116.1-SK6-A2	A2	11 - 23	10	9.5	110
GN 116.1-SK6-A3	A3	19 - 31	12	-	110
GN 116.1-SK6-A4	A4	27 - 39	12	20	110
GN 116.1-SK6-A5	A5	34 - 46	12	15	111
GN 116.1-VDE-A1	A1	4 - 16	6	9.5	107
GN 116.1-VDE-A2	A2	11 - 23	10	9.5	107
GN 116.1-VDE-A3	A3	19 - 31	12	-	108
GN 116.1-VDE-A4	A4	27 - 39	12	20	108
GN 116.1-VDE-A5	A5	34 - 46	12	15	109
GN 116.1-VK7-A1	A1	4 - 16	6	9.5	102
GN 116.1-VK7-A2	A2	11 - 23	10	9.5	103
GN 116.1-VK7-A3	A3	19 - 31	12	-	104
GN 116.1-VK7-A4	A4	27 - 39	12	20	106
GN 116.1-VK7-A5	A5	34 - 46	12	15	107
GN 116.1-VK8-A1	A1	4 - 16	6	9.5	104
GN 116.1-VK8-A2	A2	11 - 23	10	9.5	104
GN 116.1-VK8-A3	A3	19 - 31	12	-	105
GN 116.1-VK8-A4	A4	27 - 39	12	20	105
GN 116.1-VK8-A5	A5	34 - 46	12	15	106

