



Full cone
nozzles

Full cone nozzles

-
- Absorption
 - Chemical process engineering
 - Chlorine precipitation
 - Cleaning
 - Cooling
 - Desuperheating
 - Dust control
 - Fire protection
 - Foam control
 - Gas treatment
 - Spraying onto mats in air washers
 - Spraying over packings
 - Surface spraying
 - Water treatment
 - and many others...



Full cone nozzles

Axial-flow full cone nozzles

Lechler full cone nozzles have an extraordinarily uniform liquid distribution over the whole circular impact area. The high precision of distribution is achieved by orienting the liquid inlet to the centre of the swirl chamber of the nozzle. The optimized x-style swirl insert ensures a high operating safety due to its large free cross-sections.

Axial-flow full cone nozzles are available with different spray angles and in many flow rates. Therefore, matching to specific service conditions is possible without any difficulties.

- Extremely uniform liquid distribution
- Wide flow rate range
- Large number of available spray angles



Special design for fire fighting: Deflector-plate nozzle

Tangential flow full cone nozzles

Tangential-flow full cone nozzles are, for instance, particularly suited for closed-circuit spraying of liquids with a high quota of solid matter, or for fire fighting applications. The atomizing fluid is tangentially supplied to a swirl chamber, where it is put into rotation. Tangential-flow full cone nozzles are free of swirl inserts. Hence, they are not at all prone to clogging. The full cone spray is obtained with the aid of specially arranged grooves, milled into the nozzle bottom, which cause an adequate part of the rotating liquid flow to diverge to the center of the

swirl chamber. Thereby, an extremely uniform area distribution of the sprayed liquid is achieved.

- Reliable in service
- Non-clogging
- Stable spray angles, unaffected by transient pressures

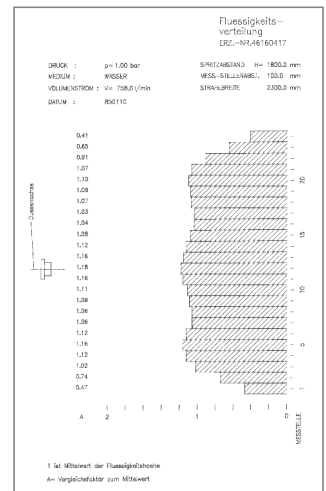

Typical liquid distribution chart

Cluster Head Nozzles

Lechler cluster head nozzles achieve a very large surface of the sprayed liquid by adding various finely atomizing single nozzles. Whenever a fine fog-like full cone atomization with relatively large flow rates is necessary, e.g. gas exchange processes, steam cooling or dust suppression, Lechler cluster head nozzles have decisive advantages: overlapping hollow cones form a fine full cone atomization with an increased droplet surface area. These very fine droplets cannot be achieved by a

single-orifice spray nozzle of the same flow rate size.

The increased droplet surface area of the atomized liquid provides great efficiency in gas treatment and cooling applications.

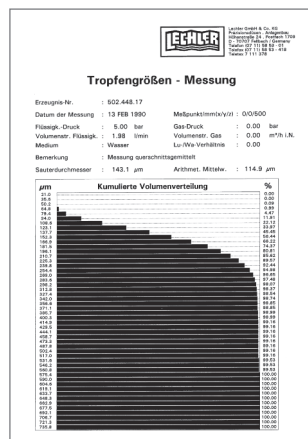

Cumulated volume distribution

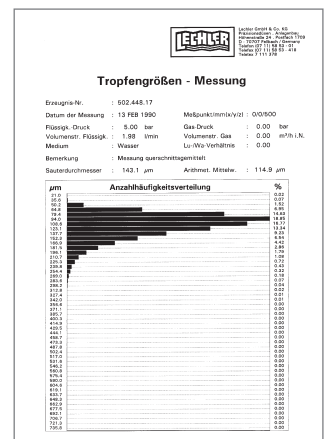







Number distribution





Full cone nozzles

Axial-flow full cone nozzles	Series		\dot{V} [l/min] at $p = 2$ bar	Connection	Application/ Design	Page
	490 491	45° 60° 90° 120°	0.63 – 71.00	1/8 BSPT 1/4 BSPT 3/8 BSPT 1/2 BSPT 3/4 BSPP 1 BSPP	Cleaning and washing processes, surface spraying, Container cleaning, foam precipitation, degassing of liquids. Non-clogging nozzle design.	3.5
	460 461	60° 90° 120°	0.40 – 71.00	1/8 BSPT 1/4 BSPT 3/8 BSPT 1/2 BSPT 3/4 BSPP 1 BSPP	Cleaning and washing process, cooling of gaseous fluids and solids, surface spraying, spraying onto mats in air washers, improving on chemical reactions. Large free cross-sections, due to optimized x-style swirl insert.	3.7
	405	60° 90° 120°	100.00 – 315.00	1 1/4 BSPP 1 1/2 BSPP 2 BSPP	Surface spraying, spraying over packings, cleaning and washing process, chemical process engineering, cooling of gaseous fluids and solids, water treatment. Uniform full cone spray.	3.9
	403	90° 120°	400.00 – 1250.00	2 1/2 BSPP 3 BSPP 3 1/2 BSPP 4 BSPP	Surface spraying, spraying over packings, cleaning and washing process, chemical process engineering, cooling of gaseous fluids and solids, water treatment. Uniform full cone spray.	3.10
	468	60° 90° 120°	0.63 – 12.50	Assembly with 3/8" retaining nut	Surface spraying, spraying over packings, chemical process engineering, cleaning and washing processes, cooling of gaseous fluids and solids. Uniform full cone spray.	3.11



Full cone nozzles

Tangential-flow full cone nozzles	Series		\dot{V} [l/min] at $p = 2$ bar	Connection	Application/ Design	Page
	422 423	60° 90° 120°	1.00 – 100.00	1/4 BSPT 3/8 BSPT 1/2 BSPT 3/4 BSPT 1 BSPT	Cleaning and washing process, cooling of gaseous fluids and solids, surface spraying, spraying onto mats in air washers, improving on chemical reactions, continuous casting. Without swirl inserts, non-clogging.	3.12 3.13
	422 Bayonet quick-release system	60° 90° 120°	1.00 – 4.00	Assembly with bayonet quick-release system	Cleaning problems, cooling process, foam control. Quick and safe assembly, without tools. Space-saving installation.	3.14
Cluster head nozzles	Series		\dot{V} [l/min] at $p = 2$ bar	Connection	Application/ Design	Page
	502 503	70° 130°	1.25 – 60.00	1/2 BSPP 3/4 BSPP	Cooling of gaseous and solid material, desuperheating, chlorine precipitation, absorption as well as for improvement of chemical reaction by enlarging the contact area. Fine full cone atomization with the aid of several hollow cones spraying into one another.	3.15
	520 523	130°	8.50 – 90.00	1 BSPP	Fire fighting, cooling of gaseous and solid material, chlorine precipitation. Extremely fine full cone atomization with the aid of several hollow cones spraying into one another.	On request. For further informations please refer to our brochure »Lechler nozzles for fire fighting«
Deflector-plate nozzle	Series		\dot{V} [l/min] at $p = 2$ bar	Connection	Application/ Design	Page
	524 525	180°	10.0 – 140.00	1/2 BSPP	Fire fighting and broadcast spraying. Non-clogging nozzle without swirl inserts.	3.16



Axial-flow full cone nozzles

Series 490 / 491

NEW Patent pending



Non-clogging nozzle design. Stable spray angle. Particularly even liquid distribution.

Applications:

Cleaning and washing processes, surface spraying, Container cleaning, foam precipitation, degassing of liquids.



Series 490/491 represents a new generation within the axial-flow full cone nozzles product group. These nozzles were developed using state-of-the-art design and simulation methods (CFD).

Nozzles of series 490/491 replace series 460/461 which are still available on request.

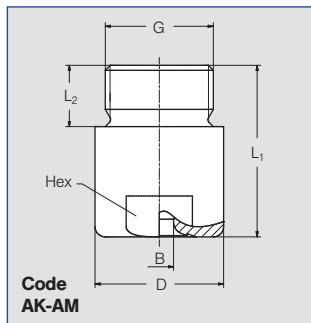
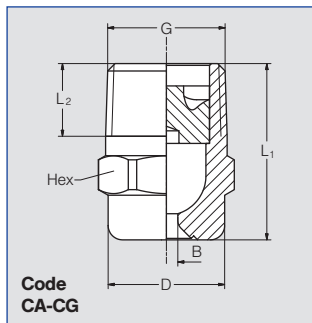

Code	G	Dimensions [mm]			Hex	Weight Brass
		L ₁	L ₂	D		
CA	1/8 BSPT	18.0	6.5	10.0	11	13 g
CC	1/4 BSPT	22.0	10.0	13.0	14	16 g
CE	3/8 BSPT	24.5	10.0	16.0	17	30 g
CE	3/8 BSPT	30.0	10.0	16.0	17	50 g
CG	1/2 BSPT	32.5	13.0	21.0	22	60 g
CG	1/2 BSPT	43.5	13.0	21.0	22	85 g
AK	3/4 BSPP	42.0	15.0	32.0	27	190 g
AM	1 BSPP	56.0	17.0	40.0	36	350 g

Subject to technical modification.

In a critical installation situation, please ask for the exact dimensions.

Spray angle	Ordering no.								B Ø [mm]	E Ø [mm]	ṽ [l/min]							Spray diameter D at p=2 bar		
	Type	Mat. no.		Code							p [bar]							Diagram		
		1Y	30	AISI 316L	Brass	1/8 BSPT	1/4 BSPT	3/8 BSPT			1/2 BSPT	3/4 BSPP	1 BSPP	0.5	1.0	2.0	3.0	5.0	7.0	10.0
45°	490.403	○	○	CA	-	-	-	-	-	1.25	1.25	0.57	0.76	1.00	1.18	1.44	1.65	1.90	160	400
	490.523	○	○	CA	-	-	-	-	-	1.70	1.70	1.15	1.52	2.00	2.35	2.89	3.30	3.81	160	400
	490.603	○	○	-	CC	CE*	-	-	-	2.00	2.00	1.81	2.39	3.15	3.70	4.54	5.20	6.00	160	400
	490.643	-	○	-	-	CE	-	-	-	2.45	2.45	2.30	3.03	4.00	4.70	5.77	6.60	7.61	160	400
	490.683	-	○	-	-	CE	-	-	-	2.55	2.55	2.87	3.79	5.00	5.88	7.21	8.25	9.52	160	400
	490.703	-	○	-	-	CE	-	-	-	2.65	2.65	3.22	4.24	5.60	6.59	8.08	9.24	10.66	160	400
	490.723	○	○	-	-	CE	-	-	-	2.85	2.85	3.62	4.77	6.30	7.41	9.09	10.40	11.99	160	400
	490.783	-	○	-	-	-	CG	-	-	3.45	3.45	5.17	6.82	9.00	10.58	12.98	14.85	17.12	160	400
	490.843	-	○	-	-	-	CG	-	-	3.80	3.80	7.18	9.47	12.50	14.70	18.03	20.63	23.80	160	400
60°	490.404	○	○	CA	-	-	-	-	-	1.15	1.15	0.57	0.76	1.00	1.18	1.44	1.65	1.90	220	560
	490.444	○	-	CA	-	-	-	-	-	1.25	1.25	0.72	0.95	1.25	1.47	1.80	2.06	2.38	220	560
	490.484	○	○	CA	-	-	-	-	-	1.45	1.45	0.92	1.21	1.60	1.88	2.31	2.64	3.05	220	560
	490.524	○	○	CA	-	-	-	-	-	1.60	1.60	1.15	1.52	2.00	2.35	2.89	3.30	3.81	220	560
	490.564	○	○	CA	-	-	-	-	-	1.80	1.80	1.44	1.89	2.50	2.94	3.61	4.13	4.76	220	560
	490.604	○	○	CA	CC	CE	-	-	-	2.05	2.05	1.81	2.39	3.15	3.70	4.54	5.20	6.00	220	560
	490.644	○	○	-	CC	CE	-	-	-	2.30	2.30	2.30	3.03	4.00	4.70	5.77	6.60	7.61	220	560
	490.684	○	○	-	CC	CE	-	-	-	2.60	2.60	2.87	3.79	5.00	5.88	7.21	8.25	9.52	220	560
	490.724	○	○	-	CC	CE	-	-	-	2.95	2.80	3.62	4.77	6.30	7.41	9.09	10.40	11.99	220	560
	490.764	○	○	-	-	CE	-	-	-	3.25	3.25	4.59	6.06	8.00	9.41	11.54	13.20	15.22	220	560
	490.804	○	○	-	-	CE	-	-	-	3.70	3.70	5.74	7.58	10.00	11.76	14.43	16.51	19.04	220	560
	490.844	○	○	-	-	-	CG	-	-	4.05	4.05	7.18	9.47	12.50	14.70	18.03	20.63	23.80	220	560
	490.884	○	○	-	-	-	CG	-	-	4.65	4.65	9.19	12.13	16.00	18.82	23.08	26.41	30.46	220	560
	490.924	○	○	-	-	-	-	AK	-	5.20	5.20	11.49	15.16	20.00	23.52	28.85	33.01	38.07	220	560
	490.964	○	○	-	-	-	-	AK	-	5.80	5.80	14.36	18.95	25.00	29.40	36.07	41.26	47.59	220	560
	491.044	○	○	-	-	-	-	-	AM	7.25	7.25	22.97	30.31	40.00	47.04	57.71	66.02	76.15	220	560
	491.084	○	○	-	-	-	-	-	AM	8.15	8.15	28.72	37.89	50.00	58.80	72.14	82.53	95.18	220	560

*Only available in material 30 · B = bore diameter · E = narrowest free cross section

Continued on next page.

Conversion formula for the above series: $\dot{V}_2 = \dot{V}_1 * \left(\frac{p_2}{p_1}\right)^{0.4}$ (≤ 10 bar)





Axial-flow full cone nozzles

Series 490 / 491

NEW Patent pending



Spray angle	Ordering no.									B Ø [mm]	E Ø [mm]	\dot{V} [l/min]							Spray diameter D at p=2 bar	
	Type	Mat. no.		Code								p [bar]								
		1Y	30	1/8 BSPT	1/4 BSPT	3/8 BSPT	1/2 BSPT	3/4 BSPP	1 BSPP			0.5	1.0	2.0	3.0	5.0	7.0	10.0		
		AISI 316L	Brass																	
90°	490.406	○	○	CA	-	-	-	-	-	1.20	1.20	0.57	0.76	1.00	1.18	1.44	1.65	1.90	380	860
	490.446	-	○	CA	-	-	-	-	-	1.30	1.30	0.72	0.95	1.25	1.47	1.80	2.06	2.38	380	860
	490.486	○	○	CA	-	-	-	-	-	1.45	1.45	0.92	1.21	1.60	1.88	2.31	2.64	3.05	380	860
	490.526	○	○	CA	-	-	-	-	-	1.70	1.55	1.15	1.52	2.00	2.35	2.89	3.30	3.81	380	860
	490.566	○	○	CA	-	-	-	-	-	1.90	1.90	1.44	1.89	2.50	2.94	3.61	4.13	4.76	380	860
	490.606	○	○	CA	-	CE	-	-	-	2.10	2.05	1.81	2.39	3.15	3.70	4.54	5.20	6.00	380	860
	490.646	○	○	-	CC	CE	-	-	-	2.40	2.40	2.30	3.03	4.00	4.70	5.77	6.60	7.61	390	960
	490.686	○	○	-	CC	CE	-	-	-	2.70	2.70	2.87	3.79	5.00	5.88	7.21	8.25	9.52	390	960
	490.726	○	○	-	CC	CE	-	-	-	3.20	2.80	3.62	4.77	6.30	7.41	9.09	10.40	11.99	390	960
	490.746	○	○	-	-	CE	-	-	-	3.15	3.15	4.08	5.38	7.10	8.35	10.24	11.72	13.52	390	960
	490.766	○	○	-	-	CE	-	-	-	3.40	3.40	4.59	6.06	8.00	9.41	11.54	13.20	15.22	390	960
	490.806	○	○	-	-	CE	-	-	-	3.90	3.90	5.74	7.58	10.00	11.76	14.43	16.51	19.04	390	960
	490.846	○	○	-	-	CE	-	-	-	4.65	4.00	7.18	9.47	12.50	14.70	18.03	20.63	23.80	390	960
	490.886	○	○	-	-	-	-	CG	-	5.45	4.50	9.19	12.13	16.00	18.82	23.08	26.41	30.46	390	960
	490.926	○	○	-	-	-	-	CG	-	5.90	4.50	11.49	15.16	20.00	23.52	28.85	33.01	38.07	390	960
	490.966	○	○	-	-	-	-	CG	AK	6.55	4.85	14.36	18.95	25.00	29.40	36.07	41.26	47.59	390	960
	491.006	○	○	-	-	-	-	-	AK	7.55	5.50	18.09	23.87	31.50	37.05	45.45	51.99	59.97	390	960
	491.046	○	○	-	-	-	-	-	AK	8.60	6.60	22.97	30.31	40.00	47.04	57.71	66.02	76.15	390	960
	491.086	○	○	-	-	-	-	-	AM	9.45	7.25	28.72	37.89	50.00	58.80	72.14	82.53	95.18	390	960
	491.126	○	○	-	-	-	-	-	AM	10.40	8.00	36.18	47.75	63.00	74.09	90.89	103.98	119.93	390	960
491.146	○	-	-	-	-	-	-	AM	11.00	7.50	40.78	53.81	71.00	83.50	102.43	117.19	135.16	390	960	
120°	490.368	○	○	CA	-	-	-	-	-	0.85	0.65	0.36	0.48	0.63	0.74	0.91	1.04	1.20	680	1220
	490.408	○	○	CA	-	-	-	-	-	1.20	1.20	0.57	0.76	1.00	1.18	1.44	1.65	1.90	680	1220
	490.448	○	○	CA	-	-	-	-	-	1.30	1.30	0.72	0.95	1.25	1.47	1.80	2.06	2.38	680	1220
	490.488	○	○	CA	-	-	-	-	-	1.45	1.45	0.92	1.21	1.60	1.88	2.31	2.64	3.05	680	1220
	490.528	○	○	CA	-	-	-	-	-	1.70	1.70	1.15	1.52	2.00	2.35	2.89	3.30	3.81	680	1220
	490.568	○	○	CA	-	-	-	-	-	1.90	1.90	1.44	1.89	2.50	2.94	3.61	4.13	4.76	680	1220
	490.608	○	○	CA	-	-	-	-	-	2.10	2.05	1.81	2.39	3.15	3.70	4.54	5.20	6.00	680	1220
	490.648	○	○	-	CC	CE	-	-	-	2.40	2.40	2.30	3.03	4.00	4.70	5.77	6.60	7.61	680	1330
	490.688	○	○	-	CC	CE	-	-	-	2.75	2.75	2.87	3.79	5.00	5.88	7.21	8.25	9.52	680	1330
	490.728	○	○	-	CC	CE	-	-	-	3.20	2.80	3.62	4.77	6.30	7.41	9.09	10.40	11.99	680	1330
	490.748	○	○	-	-	CE	-	-	-	3.20	3.20	4.08	5.38	7.10	8.35	10.24	11.72	13.52	680	1330
	490.768	○	○	-	-	CE	-	-	-	3.45	3.45	4.59	6.44	8.00	9.41	11.54	13.20	15.22	680	1330
	490.808	○	○	-	-	CE	-	-	-	3.90	3.90	5.74	7.58	10.00	11.76	14.43	16.51	19.04	680	1330
	490.848	○	○	-	-	CE	-	-	-	4.70	4.00	7.18	9.47	12.50	14.70	18.03	20.63	23.80	680	1330
	490.888	○	○	-	-	-	-	CG	-	5.10	4.50	9.19	12.13	16.00	18.82	23.08	26.41	30.46	680	1330
	490.928	○	○	-	-	-	-	CG	-	5.80	4.75	11.49	15.16	20.00	23.52	28.85	33.01	38.07	680	1330
	490.968	○	○	-	-	-	-	CG	AK	6.65	4.85	14.36	18.95	25.00	29.40	36.07	41.26	47.59	680	1330
	491.048	○	○	-	-	-	-	-	AK	9.20	5.85	22.97	30.31	40.00	47.04	57.71	66.02	76.15	680	1330
	491.128	○	○	-	-	-	-	-	AM	10.80	7.75	36.18	47.75	63.00	74.09	90.89	103.98	119.93	680	1330
	491.148	○	-	-	-	-	-	-	AM	11.40	7.65	40.78	53.81	71.00	83.50	102.43	117.19	135.16	680	1330

B = bore diameter · E = narrowest free cross section

Other nozzle materials (special alloys, plastics) are available on request.

Example	Type	+	Material no.	+	Code	=	Ordering no.
for ordering:	490.406	+	1Y	+	CA	=	490.406.1Y.CA



Conversion formula for the above series: $\dot{V}_2 = \dot{V}_1 * \left(\frac{p_2}{p_1}\right)^{0,4}$ (≤ 10 bar)



Axial-flow full cone nozzles

Series 460 / 461



**Very uniform spray pattern.
Large free cross-sections,
due to optimized
x-style swirl insert.**

Applications:

Cleaning and washing process, cooling of gaseous fluids and solids, surface spraying, spraying onto mats in air washers, improving of chemical reactions.

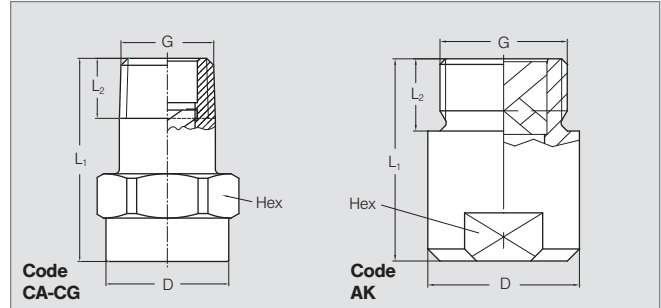

Code	Dimensions [mm]				
	G	L ₁	L ₂	D	Hex
CA	1/8 BSPT	22.0	6.5	13.0	14
CC	1/4 BSPT	22.0	9.7	13.0	14
CE	3/8 BSPT	30.0	10.0	17.0	17
CG	1/2 BSPT	43.5	13.2	22.0	22
AK	3/4 BSPP	42.0	15.0	31.5	27

Subject to technical modifications.
Please enquire about the exact
dimensions if the installation situation
is critical!

Spray angle	Type	Mat.-no. 5E	Ordering no.					B ∅ [mm]	E ∅ [mm]	V̇ [l/min]								Spray diameter D at p=2 bar			
			Code							p [bar]								H = 200 mm		H = 500 mm	
			PVDF	1/8 BSPT	1/4 BSPT	3/8 BSPT	1/2 BSPT			3/4 BSPP	0.5	1.0	2.0	3.0	5.0	7.0	10.0	D	H	D	H
60°	460.644	○	-	CC	-	-	2.40	1.90	2.30	3.03	4.00	4.70	5.77	6.60	7.61	220	560				
	460.964	○	-	-	-	AK	5.80	4.90	14.36	18.95	25.00	29.40	36.07	41.26	47.59	220	560				
90°	460.326	○	CA	-	-	-	0.80	0.55	0.23	0.30	0.40	0.47	0.58	0.66	0.76	380	860				
	460.406	○	CA	-	-	-	1.20	0.85	0.57	0.76	1.00	1.18	1.44	1.65	1.90	380	860				
	460.486	○	CA	-	-	-	1.45	1.20	0.92	1.21	1.60	1.88	2.31	2.64	3.05	380	860				
	460.526	○	CA	-	-	-	1.65	1.30	1.15	1.52	2.00	2.35	2.89	3.30	3.81	380	860				
	460.606	○	CA	-	CE	-	2.05	1.45	1.81	2.39	3.15	3.70	4.54	5.20	6.00	380	860				
	460.646	○	-	CC	-	-	2.30	1.80	2.30	3.03	4.00	4.70	5.77	6.60	7.61	390	960				
	460.726	○	-	-	CE	-	2.95	2.00	3.62	4.77	6.30	7.41	9.09	10.40	11.99	390	960				
	460.746	○	-	-	CE	-	3.30	1.90	4.08	5.38	7.10	8.35	10.24	11.72	13.52	390	960				
	460.766	○	-	-	CE	-	3.30	2.40	4.59	6.06	8.00	9.41	11.54	13.20	15.22	390	960				
	460.806	○	-	-	CE	-	3.70	2.70	5.74	7.58	10.00	11.76	14.43	16.51	19.04	390	960				
	460.846	○	-	-	CE	-	4.05	3.20	7.18	9.47	12.50	14.70	18.03	20.63	23.80	390	960				
	460.886	○	-	-	-	CG	4.70	3.10	9.19	12.13	16.00	18.82	23.08	26.41	30.46	390	960				
	460.966	○	-	-	-	CG	5.80	3.80	14.36	18.95	25.00	29.40	36.07	41.26	47.59	390	960				
	461.006	○	-	-	-	CG	6.40	3.80	18.09	23.87	31.50	37.05	45.45	51.99	59.97	390	960				
461.046	⊗	-	-	-	AK	7.20	5.30	22.97	30.31	40.00	47.04	57.71	66.02	76.15	390	960					

B = bore diameter · E = narrowest free cross section
⊗ Material PP (Material no. 53), connection 3/4 BSPT (Code CK)

Continued on next page.

Conversion formula for the above series: $\dot{V}_2 = \dot{V}_1 * \left(\frac{p_2}{p_1}\right)^{0.4}$
(≤ 10 bar)





Axial-flow full cone nozzles

Series 460 / 461

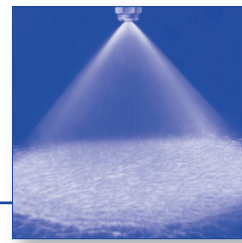

Spray angle	Ordering no.							B Ø [mm]	E Ø [mm]	V̇ [l/min]							Spray diameter D at p=2 bar	
	Type	Mat.-no. 5E	Code				p [bar]											
			1/8 BSPT	1/4 BSPT	3/8 BSPT	1/2 BSPT	3/4 BSPT			0.5	1.0	2.0	3.0			5.0	7.0	10.0
120°	460. 408	○	CA	-	-	-	-	1.20	0.85	0.57	0.76	1.00	1.18	1.44	1.65	1.90	680	1220
	460. 488	○	CA	-	-	-	-	1.50	1.00	0.92	1.21	1.60	1.88	2.31	2.64	3.05	680	1220
	460. 528	○	CA	-	-	-	-	1.65	1.20	1.15	1.52	2.00	2.35	2.89	3.30	3.81	680	1220
	460. 608	○	CA	-	-	-	-	2.10	1.40	1.81	2.39	3.15	3.70	4.54	5.20	6.00	680	1220
	460. 648	○	-	CC	-	-	-	2.45	1.60	2.30	3.03	4.00	4.70	5.77	6.60	7.61	680	1330
	460. 728	○	-	-	CE	-	-	3.10	1.90	3.62	4.77	6.30	7.41	9.09	10.40	11.99	680	1330
	460. 748	○	-	-	CE	-	-	3.30	1.90	4.08	5.38	7.10	8.35	10.24	11.72	13.52	680	1330
	460. 768	○	-	-	CE	-	-	3.50	1.90	4.59	6.44	8.00	9.41	11.54	13.20	15.22	680	1330
	460. 808	○	-	-	CE	-	-	3.80	2.40	5.74	7.58	10.00	11.76	14.43	16.51	19.04	680	1330
	460. 848	○	-	-	CE	-	-	4.20	2.70	7.18	9.47	12.50	14.70	18.03	20.63	23.80	680	1330
	460. 888	○	-	-	-	CG	-	4.60	3.10	9.19	12.13	16.00	18.82	23.08	26.41	30.46	680	1330
	460. 968	○	-	-	-	CG	-	5.90	4.10	14.36	18.95	25.00	29.40	36.07	41.26	47.59	680	1330
	461. 048	⊗	-	-	-	-	AK	7.60	4.90	22.97	30.31	40.00	47.04	57.71	66.02	76.15	680	1330

B = bore diameter · E = narrowest free cross section

⊗ Material PP (Material no. 53), connection 3/4 BSPT (Code CK)

The folded page at the end of the catalogue will give you a survey on the various assembly possibilities.

For complete assembly accessories, please refer to »Accessories«.

Example Type + Material-no. + Code = Ordering no.
for ordering: 460. 408 + 5E + CA = 460. 408. 5E. CA



Axial-flow full cone nozzles

Series 405



Very uniform spray pattern.

Applications:

Surface spraying, spraying over packings, cleaning and washing process, chemical process engineering, cooling of gaseous fluids and solids, water treatment.

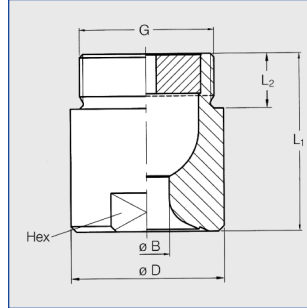
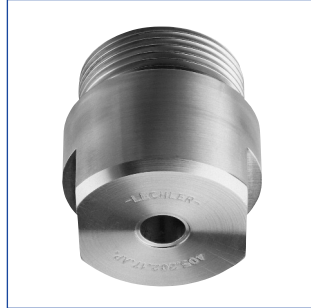

Dimensions [mm]				
G	L ₁	L ₂	D	Hex
1 1/4 BSPP	50	19	49	41
1 1/2 BSPP	60	19	59	50
2 BSPP	78	24	68	60

Spray angle	Ordering no.					B ∅ [mm]	E ∅ [mm]	V̇ [l/min]						Spray diameter D at p=2 bar		
	Type	Mat.-no.		Code				p [bar]						H =		
		1Y	30					0.3	0.5	1.0	2.0	3.0	5.0	0.5 m	1 m	
		AISI 316L	Brass	1 1/4 BSPP	1 1/2 BSPP	2 BSPP										
60°	405. 204	●	●	AP	-	-	11.20	5.80	47	57	76	100	118	144	560	1040
	405. 284	●	●	-	AR	-	14.30	7.00	75	92	121	160	188	231	580	1080
	405. 324	●	●	-	-	AV	16.40	7.50	94	115	152	200	235	289	580	1080
	405. 364	●	●	-	-	AV	18.40	8.50	117	144	189	250	294	361	580	1080
	405. 404	●	●	-	-	AV	20.00	7.00	147	181	239	315	370	454	580	1100
90°	405. 206	●	●	AP	-	-	12.00	5.00	47	57	76	100	118	144	780	1450
	405. 286	●	●	-	AR	-	15.20	6.20	75	92	121	160	188	231	800	1550
	405. 326	●	●	-	-	AV	17.20	7.70	94	115	152	200	235	289	850	1600
	405. 366	●	●	-	-	AV	19.50	8.70	117	144	189	250	294	361	850	1600
	405. 406	●	●	-	-	AV	22.00	9.50	147	181	239	315	370	454	850	1600
120°	405. 208	●	●	AP	-	-	12.70	5.00	47	57	76	100	118	144	1450	2600
	405. 288	●	●	-	AR	-	16.00	6.60	75	92	121	160	188	231	1500	2700
	405. 328	●	●	-	-	AV	17.80	7.90	94	115	152	200	235	289	1500	2800
	405. 368	●	●	-	-	AV	20.10	8.80	117	144	189	250	294	361	1500	2800
	405. 408	●	●	-	-	AV	22.40	9.10	147	181	239	315	370	454	1500	2800

B = bore diameter · E = narrowest free cross section

Example Type + Material-no. + Code = Ordering no.
for Ordering: 405. 204 + 1Y + AP = 405. 204. 1Y. AP

Conversion formula for the above series: $\dot{V}_2 = \dot{V}_1 * \left(\frac{p_2}{p_1}\right)^{0,4}$
 (≤ 10 bar)





Axial-flow full cone nozzles

Series 403

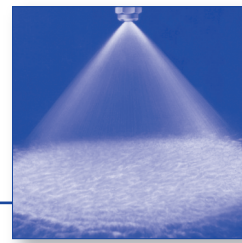

Very uniform spray pattern.

Applications:
Surface spraying, spraying over packings, chemical process engineering, cooling of gaseous fluids and solids.

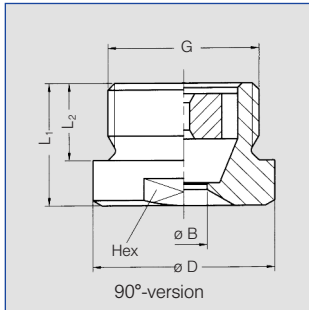
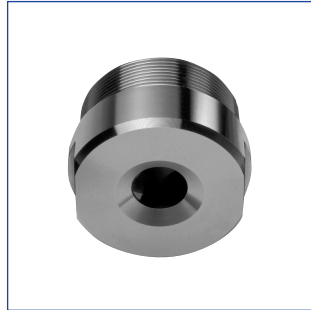

90°-version

Dimensions [mm]						
Type	G ISO 228	L ₁	L ₂	D	Hex	
403.446/403.486	G 2 1/2 A	52	27	83	75	
403.526	G 3 A	60	30	98	85	
403.606	G 3 1/2 A	70	32	118	105	

120°-version

Dimensions [mm]						
Type	G ISO 228	L ₁	L ₂	D	Hex	
403.448/403.488	G 2 1/2 A	124	27	83	75	
403.528	G 3 A	153	30	98	85	
403.608	G 3 1/2 A	156	32	118	105	
403.628	G 4 A	165	36	128	110	

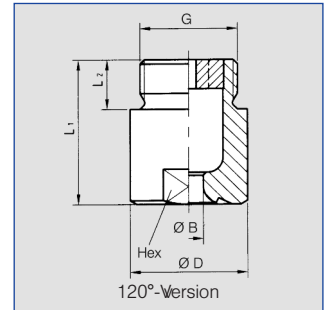

Spray angle	Ordering no.		B ø [mm]	E ø [mm]	\dot{V} [l/min]							Spray diameter D at p=2 bar	
	Type	Mat.-no.			p [bar]							 H = 0.5 m H = 1 m	
					0.3	0.5	1.0	2.0	3.0	5.0	7.0		
90°	403.446	○	25.00	12.00	187	230	303	400	470	577	660	900	1700
	403.486	○	29.50	12.00	234	287	379	500	588	721	825	900	1700
	403.526	○	32.00	13.80	295	362	477	630	741	909	1040	900	1700
	403.606	○	40.00	15.00	468	574	758	1000	1176	1443	1651	980	1750
120°	403.448	○	25.50	10.00	187	230	303	400	470	577	660	1500	2850
	403.488	○	29.50	11.00	234	287	379	500	588	721	825	1500	2850
	403.528	○	32.00	15.00	295	362	477	630	741	909	1040	1500	2850
	403.608	○	42.00	12.00	469	574	758	1000	1176	1443	1651	1500	2850
	403.628	○	45.00	15.00	585	718	947	1250	1470	1903	2063	1600	2900

B = bore diameter · E = narrowest free cross section

Example for ordering:	Type	+	Material-no.	=	Ordering no.
	403.446	+	1Y	=	403.446.1Y



Axial-flow full cone nozzles for retaining nut

Series 468



Full cone nozzle for assembly with retaining nut. Uniform full cone spray.

Applications:

Surface spraying, spraying over packings, chemical process engineering, cleaning and washing processes, cooling of gaseous fluids and solids.

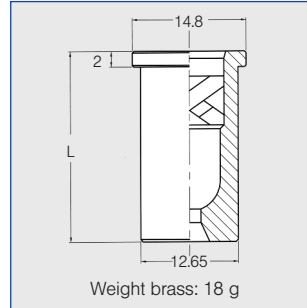

Spray angle	Ordering no.			B Ø [mm]	E Ø [mm]	V̇ [l/min]							L [mm]	Spray diameter D at p = 2 bar		
	Type	Mat.-no.				p [bar]								H = 200 mm	H = 500 mm	
		17 ¹⁾	30			5E	0.5	1.0	2.0	[US gal./min] at 40 psi	3.0	5.0				10.0
60°	468. 604	●	●	-	2.05	1.40	1.81	2.39	3.15	0.98	3.70	4.54	6.00	18	220	560
	468. 644	-	●	●	2.40	1.90	2.30	3.03	4.00	1.20	4.70	5.77	7.61	24.5	220	560
	468. 684	-	●	-	2.60	2.00	2.87	3.79	5.00	1.55	5.88	7.21	9.52	24.5	220	560
	468. 724	●	●	-	2.90	2.00	3.62	4.77	6.30	1.89	7.41	9.09	11.99	24.5	220	560
90°	468. 526	●	●	●	1.65	1.30	1.15	1.52	2.00	0.60	2.35	2.89	3.81	18	380	860
	468. 846	●	●	-	4.05	3.20	7.18	9.47	12.50	3.75	14.70	18.03	23.80	24.5	380	960
120°	468. 368	-	●	-	0.95	0.70	0.36	0.48	0.63	0.20	0.74	0.91	1.20	18	680	1540
	468. 408	●	●	-	1.20	0.85	0.57	0.76	1.00	0.30	1.18	1.44	1.90	18	680	1540
	468. 488	●	●	-	1.50	1.00	0.92	1.21	1.60	0.48	1.88	2.31	3.05	18	680	1540
	468. 528	●	●	-	1.65	1.20	1.15	1.52	2.00	0.60	2.35	2.89	3.81	18	680	1540

¹⁾ We reserve the right to deliver AISI 316Ti or AISI 316L under the material no. 17. B = bore diameter · E = narrowest free cross section

The folded page at the end of the catalogue will give you a survey on the various assembly possibilities. For complete assembly accessories, please refer to »Accessories«.

Example for ordering	Type	+	Material-no.	=	Ordering no.
	468. 604	+	17	=	468. 604. 17

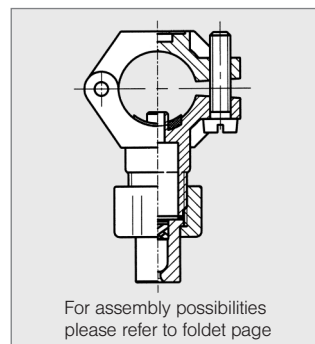

Conversion formula for the above series: $\dot{V}_2 = \dot{V}_1 * \left(\frac{p_2}{p_1}\right)^{0,4}$ (≤ 10 bar)





Tangential-flow full cone nozzles

Series 422



Tangentially arranged liquid supply. Without swirl inserts. Non-clogging. Stable spray angle. Uniform spray.

Applications:

Cleaning and washing process, cooling of gaseous fluids and solids, surface spraying, spraying onto mats in air washers, improving on chemical reactions, continuous casting, foam control.

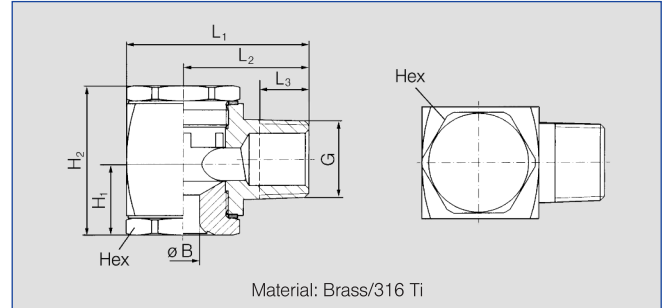
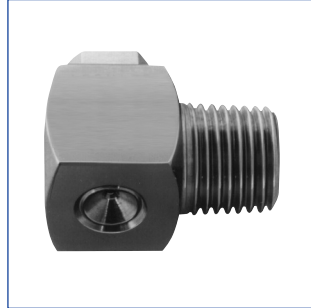

G	Dimensions [mm]						Weight Brass
	L ₁	L ₂	L ₃	H ₁	H ₂	Hex	
1/4 BSPT	28.0	20.0	10.0	8.0	20.5	12.0	43 g
3/8 BSPT	36.0	25.0	10.0	11.0	26.5	19.0	105 g
1/2 BSPT	48.5	33.5	13.0	20.0	40.0	27.0	250 g
3/4 BSPT	58.0	38.0	14.5	23.5	57.0	36.0	660 g
1 BSPT	76.0	48.5	17.0	27.5	66.0	41.0	1.330 g

Spray angle	Type	Ordering no.						B Ø [mm]	E Ø [mm]	V̇ [l/min]							Spray diameter D at p=1-10 bar			
		Mat.-no.		Code						p [bar]							H = 200 mm		H = 500 mm	
		30	17 ¹⁾	1/4 BSPT	3/8 BSPT	1/2 BSPT	3/4 BSPT			1 BSPT	[US gal./min] at 40 psi			3.0	5.0	10.0	D	H	D	H
		Brass	AISI 316Ti/AISI 316L								0.5	1.0	2.0							
60°	422.644	•	•	-	CE	-	-	-	3.00	3.00	2.00	2.83	4.00	1.24	4.90	6.32	8.94	225	510	
	90°	422.406	•	•	CC	-	-	-	1.50	1.45	0.50	0.71	1.00	0.31	1.22	1.58	2.24	380	860	
		422.486	-	•	CC	-	-	-	1.90	1.80	0.80	1.13	1.60	0.50	1.96	2.53	3.58	380	860	
		422.566	•	•	CC	-	-	-	2.30	2.20	1.25	1.77	2.50	0.78	3.06	3.95	5.59	380	860	
		422.606	•	•	-	CE	-	-	2.60	2.50	1.57	2.23	3.15	0.98	3.86	4.98	7.04	380	860	
		422.646	•	•	-	CE	-	-	3.00	2.90	2.00	2.83	4.00	1.24	4.90	6.32	8.94	390	960	
		422.726	•	-	-	CE	-	-	3.70	3.60	3.15	4.45	6.30	1.95	7.72	9.96	14.09	390	960	
		422.766	-	•	-	CE	-	-	4.15	4.10	4.00	5.66	8.00	2.48	9.80	12.65	17.89	390	960	
		422.806	•	-	-	CE	-	-	4.65	4.60	5.00	7.07	10.00	3.10	12.25	15.81	22.36	390	960	
422.846		•	•	-	CE	-	-	5.30	5.30	6.25	8.84	12.50	3.88	15.31	19.76	27.95	390	960		
422.886	•	•	-	CE	-	-	5.80	6.00	8.00	11.31	16.00	4.96	19.60	25.30	35.78	390	960			
422.966	-	•	-	-	CG	-	8.00	8.00	12.50	17.68	25.00	7.75	30.62	39.53	55.90	390	960			
120°	422.488	•	-	CC	-	-	-	1.90	1.90	0.80	1.13	1.60	0.50	1.96	2.53	3.58	680	1220		
	422.568	•	-	CC	-	-	-	2.40	2.40	1.25	1.77	2.50	0.78	3.06	3.95	5.59	680	1220		
	422.608	•	-	-	CE	-	-	2.60	2.50	1.57	2.23	3.15	0.98	3.86	4.98	7.04	680	1600		
	422.728	•	•	-	CE	-	-	4.00	3.90	3.15	4.45	6.30	1.95	7.72	9.96	14.09	680	1600		
	422.808	-	•	-	CE	-	-	4.65	4.60	5.00	7.07	10.00	3.10	12.25	15.81	22.36	680	1600		
	422.848	•	•	-	CE	-	-	5.20	5.10	6.25	8.84	12.50	3.88	15.31	19.76	27.95	680	1600		
	422.888	•	•	-	CE	-	-	6.60	6.00	8.00	11.31	16.00	4.96	19.60	25.30	35.78	680	1600		
	422.928	-	•	-	-	CG	-	7.30	7.30	10.00	14.14	20.00	6.20	24.49	31.62	44.72	680	1600		
	422.968	•	•	-	-	CG	-	8.00	8.00	12.50	17.68	25.00	7.75	30.62	39.53	55.90	680	1600		
	423.008	-	•	-	-	CG	-	8.70	8.70	15.75	22.27	31.50	9.77	38.88	49.81	70.44	680	1600		
	423.128	-	•	-	-	-	CK	12.70	12.30	31.50	44.55	63.00	19.54	77.16	99.61	140.87	680	1600		
	423.208	-	•	-	-	-	CM	19.00	16.00	50.00	70.71	100.00	31.00	122.47	158.11	223.61	680	1600		

¹⁾We reserve the right to deliver AISI 316Ti or AISI 316L under the material no. 17.
B = bore diameter · E = narrowest free cross section

Plastic version see next page.

Example Type + Material-no. + Code = Ordering no.
for ordering: 422.644 + 30 + CE = 422.644.30.CE

The folded page at the end of the catalogue will give you a survey on the various assembly possibilities. For complete assembly accessories, please refer to »Accessories«.

Conversion formula for the above series: $\dot{V}_2 = \dot{V}_1 \cdot \left(\frac{p_2}{p_1}\right)^{0,4}$ (≤ 10 bar)





Tangential-flow full cone nozzles

Plastic version

Series 422 / 423



Tangentially arranged liquid supply. Without swirl inserts. Non-clogging. Stable spray angle. Uniform spray.

Applications:

Cleaning and washing process, cooling of gaseous fluids and solids, surface spraying, spraying onto mats in air washers, improving on chemical reactions, foam control.

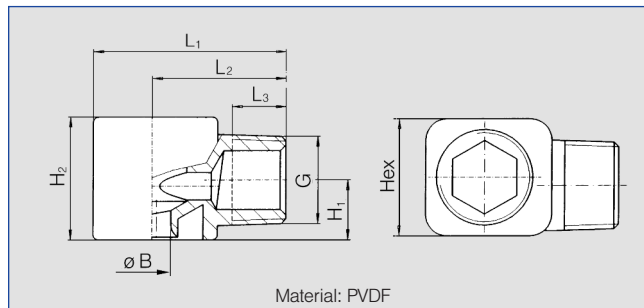

Material: PVDF

Dimensions [mm]							Weight PVDF
G	L ₁	L ₂	L ₃	H ₁	H ₂	Hex	
1/4 BSPT	28.0	20.0	9.8	8.0	16.0	16.0	7 g
3/8 BSPT	36.0	25.0	10.1	11.2	23.0	22.0	16 g
1/2 BSPT	49.5	33.5	13.2	19.2	38.0	32.0	40 g
3/4 BSPT	58.5	38.5	18.5	24.5	50.0	41.0	50 g

Spray angle	Ordering no.				B Ø [mm]	E Ø [mm]	V̇ [l/min]							Spray diameter D at p=1-10 bar				
	Type	Mat. no. 5E	Code				p [bar]							Diagram				
			PVDF	1/4 BSPT			3/8 BSPT	1/2 BSPT	3/4 BSPT	0.5	1.0	2.0	[US gal./min] at 40 psi	3.0	5.0	10.0	H = 200 mm	H = 500 mm
60°	422. 724	○	-	CE	-	-	3.60	3.60	3.15	4.45	6.30	1.95	7.72	9.96	14.09	225	510	
	90°	422. 406	○	CC	-	-	-	1.50	1.45	0.50	0.71	1.00	0.31	1.22	1.58	2.24	380	860
		422. 566	○	CC	-	-	-	2.30	2.20	1.25	1.77	2.50	0.78	3.06	3.95	5.59	380	860
		422. 606	○	-	CE	-	-	2.60	2.50	1.57	2.23	3.15	0.98	3.86	4.98	7.04	380	860
		422. 646	○	-	CE	-	-	3.00	2.90	2.00	2.83	4.00	1.24	4.90	6.32	8.94	390	960
		422. 726	○	-	CE	-	-	3.70	3.60	3.15	4.45	6.30	1.95	7.72	9.96	14.09	390	960
		422. 806	○	-	CE	-	-	4.65	4.60	5.00	7.07	10.00	3.10	12.25	15.81	22.36	390	960
		422. 846	○	-	CE	-	-	5.30	5.30	6.25	8.84	12.50	3.88	15.31	19.76	27.95	390	960
		422. 886	○	-	CE	-	-	5.80	6.00	8.00	11.31	16.00	4.96	19.60	25.30	35.78	390	960
		422. 926	○	-	-	CG	-	7.30	7.30	10.00	14.14	20.00	6.20	24.49	31.62	44.72	390	960
422. 966		○	-	-	CG	-	8.00	8.00	12.50	17.68	25.00	7.75	30.62	39.53	55.90	390	960	
423. 006	○	-	-	CG	-	8.70	8.70	15.75	22.27	31.50	9.77	38.58	49.81	70.44	390	960		
423. 126	○	-	-	-	CK	12.00	12.00	31.50	44.55	63.00	19.54	77.16	99.61	140.87	390	960		
120°	422. 408	○	CC	-	-	-	1.50	1.45	0.50	0.71	1.00	0.31	1.22	1.58	2.24	680	1220	
	422. 448	○	CC	-	-	-	1.65	1.60	0.62	0.88	1.25	0.39	1.53	1.98	2.80	680	1220	
	422. 488	○	CC	-	-	-	1.90	1.90	0.80	1.13	1.60	0.50	1.96	2.53	3.58	680	1220	
	422. 568	○	CC	-	-	-	2.40	2.40	1.25	1.77	2.50	0.78	3.06	3.95	5.59	680	1220	
	422. 728	○	-	CE	-	-	4.00	3.90	3.15	4.45	6.30	1.95	7.72	9.96	14.09	680	1600	
	422. 888	○	-	CE	-	-	6.60	6.00	8.00	11.31	16.00	4.96	19.60	25.30	35.78	680	1600	
	422. 968	○	-	-	CG	-	8.00	8.00	12.50	17.68	25.00	7.75	30.62	39.53	55.90	680	1600	
	423. 008	○	-	-	CG	-	8.70	8.70	15.75	22.27	31.50	9.77	38.58	49.81	70.44	680	1600	
	423. 128	○	-	-	-	CK	12.70	12.30	31.50	44.55	63.00	19.54	77.16	99.61	140.87	680	1600	

B = bore diameter · E = narrowest free cross section

The folded page at the end of the catalogue will give you a survey on the various assembly possibilities. For complete assembly accessories, please refer to »Accessories«.

Example of ordering: Type + Material-no. + Code = Ordering no.
422. 724 + 5E + CE = 422. 724. 5E. CE

Conversion formula for the above series: $\dot{V}_2 = \dot{V}_1 \cdot \sqrt{\frac{p_2}{p_1}}$





Tangential-flow full cone nozzles

Bayonet quick-release system

Series 422



Quick and safe assembly, without tool. Space-saving installation. Non-clogging and maintenance-free. High resistance to temperatures and chemicals.

Applications:
Cleaning problems, cooling process, foam control.

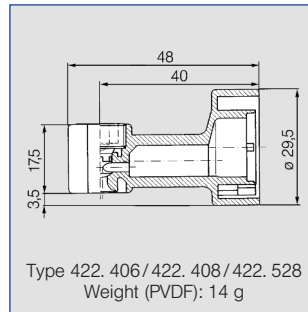
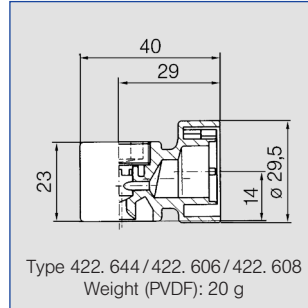
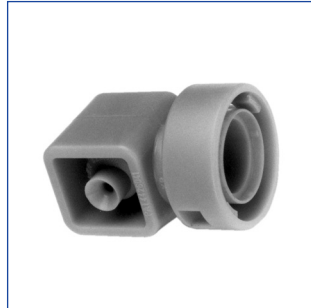

Spray angle	Ordering no.				B ∅ [mm]	E ∅ [mm]	ṽ [l/min]						Spray diameter D at p=1-10 bar		
	Type	Mat.-no.		Code			p [bar]						 H = 200 mm H = 500 mm		
		5E	53												
	PVDF	PP	Bayonet quick-release	0.5			1.0	2.0	[US gal./mm] at 40 psi	3.0	5.0	10.0			
60°	422.644	-	○	KB	2.90	2.90	2.00	2.83	4.00	1.24	4.90	6.32	8.94	225	510
	422.406	○	-	KB	1.50	1.45	0.50	0.71	1.00	0.31	1.22	1.58	2.24	380	860
90°	422.606	○	-	KB	2.60	2.50	1.57	2.23	3.15	0.98	3.86	4.98	7.04	380	860
	422.408	○	-	KB	1.50	1.45	0.50	0.71	1.00	0.31	1.22	1.58	2.24	680	1220
	422.528	○	-	KB	2.10	2.00	1.00	1.41	2.00	0.62	2.45	3.16	4.47	680	1220
120°	422.608	○	-	KB	2.60	2.50	1.57	2.23	3.15	0.98	3.86	4.98	7.04	680	1600

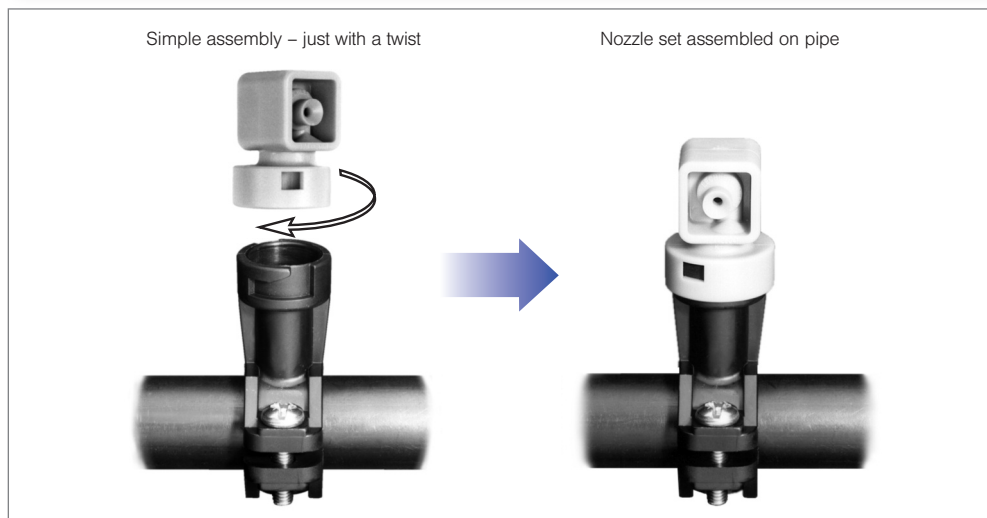

B = bore diameter
E = narrowest free cross section

The folded page at the end of the catalogue will give you a survey on the various assembly possibilities. For complete assembly accessories, please refer to »Accessories«.



Cluster head nozzles

Series 502 / 503

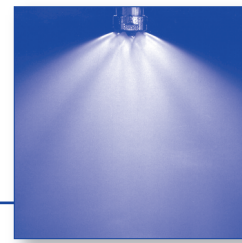

Fine full cone atomization with the aid of several hollow cones spraying into one another.

Applications:
Cooling of gaseous and solid material, desuperheating, chlorine precipitation, absorption as well as for improvement of chemical reaction by enlarging the contact area.

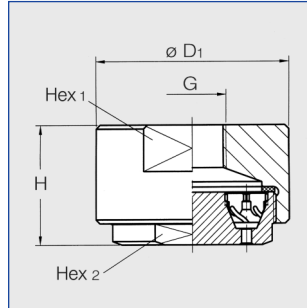

	Dimensions	
	1/2"	3/4"
Hex ₁	46	65
Hex ₂	38	55
H	25	46
D ₁	50	75
Weight (Brass)	250 g	870 g

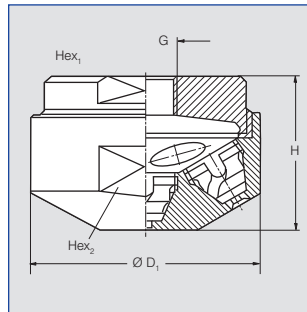
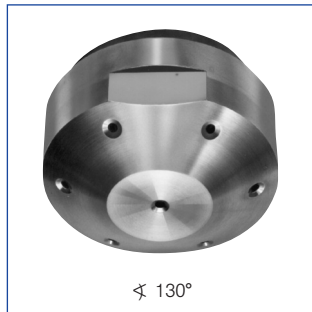

	Dimensions	
	1/2"	3/4"
Hex ₁	27	50
Hex ₂	36	55
H	28	53
D ₁	40	60
Weight (Brass)	150 g	410 g

Spray angle	Ordering no.		G	B ∅ [mm]	E ∅ [mm]	V̇ [l/min]						Spray diameter D at p = 2 bar	
	Type	Mat.-no.				p [bar]						H =	
						0.5	1.0	2.0	[US gal/min] at 40 psi	5.0	10.0	1000 mm	2000 mm
70°	502. 445	-	1/2"	1.00	0.50	-	-	1.25	0.39	1.98	2.80	400	400
	502. 985	•	3/4"	3.50	2.00	14.00	19.80	28.00	8.68	44.30	62.60	1200	1500
	503. 065	•	3/4"	5.00	2.00	22.10	31.80	45.00	13.96	71.10	100.60	1200	1800
130°	502. 448	•	1/2"	1.00	0.50	-	-	1.25	0.39	1.98	2.80	500	500
	502. 548	•	1/2"	1.80	0.50	-	1.58	2.24	0.69	3.54	5.01	700	700
	502. 748	•	3/4"	2.00	2.00	3.50	5.00	7.10	2.20	11.20	15.90	1100	1200
	502. 838	•	3/4"	3.00	2.00	4.60	8.30	11.80	3.66	18.70	26.40	1400	1600
	502. 908	•	3/4"	4.00	2.00	8.80	12.70	18.00	5.58	28.40	40.20	1500	1800
	503. 028	•	3/4"	4.00	2.00	17.70	25.10	35.50	11.01	56.10	79.40	1600	1800
503. 118	•	3/4"	6.00	2.00	30.00	42.00	60.00	18.61	95.00	134.00	2000	3000	

¹⁾We reserve the right to deliver AISI 316Ti or AISI 316L under the material no. 17.
B = bore diameter · E = narrowest free cross section

The folded page at the end of the catalogue will give you a survey on the various assembly possibilities.
For complete assembly accessories, please refer to »Accessories«.

Example for ordering:	Type	+	Material-no.	=	Ordering no.
	502. 445	+	30	=	502. 445. 30

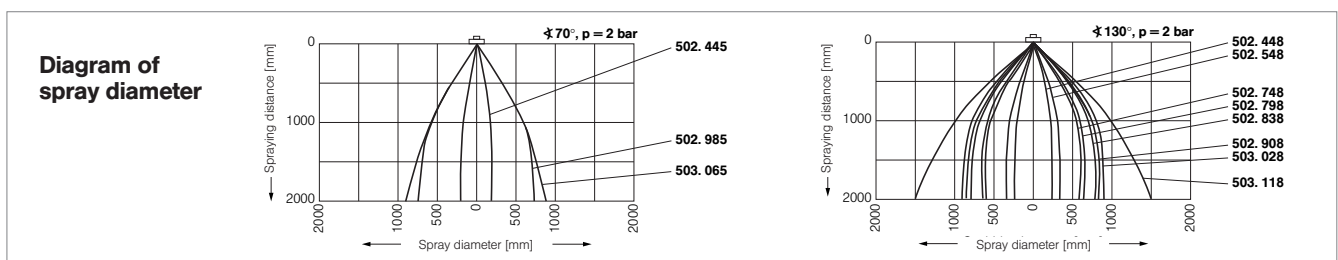

Conversion formula for the above series: $\dot{V}_2 = \dot{V}_1 \cdot \sqrt{\frac{p_2}{p_1}}$



Deflector-plate nozzle

Series 525

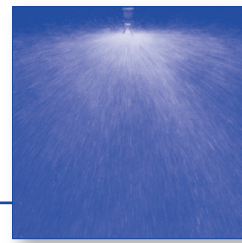

Full cone spray. Non clogging nozzle without swirl insert.

Applications:
Fire fighting and broadcast spraying, wide area spray.

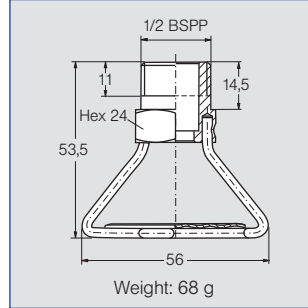

Spray angle	Ordering no.		B Ø mm	\dot{V} [l/min]						Spray diameter [D] at p=3 bar ca.	
	Type	Mat.-no.		p [bar]						 H = 1 m H = 3 m	
				0.5	1.0	[US gal./min] at 40 psi	3.0	5.0	10.0		
180°	524. 809	30 17 ¹⁾	4.00	5.00	7.10	3.10	12.20	15.80	22.40	5.60 m	6.40 m
	525. 049	30	8.00	20.00	28.30	12.41	49.00	63.20	89.40	10.00 m	13.20 m
	525. 109	30	9.30	28.00	40.00	17.37	69.00	89.00	125.00	10.20 m	13.40 m
	525. 169	30	10.90	40.00	57.00	24.81	98.00	126.00	179.00	10.60 m	13.60 m
	525. 229	30	12.20	56.00	79.00	34.73	137.00	177.00	250.00	6.80 m	10.40 m
	525. 269	30	12.30	70.00	99.00	43.42	171.00	221.00	313.00	5.20 m	10.20 m

¹⁾We reserve the right to deliver AISI 316Ti or AISI 316L under the material no. 17.
B = bore diameter

Example for ordering:	Type	+	Material-no.	=	Ordering no.
	525.809	+	30	=	525. 809. 30

Version with dust protection cap on request.



For information on further fire fighting nozzles please refer to our brochure, »Lechler nozzles for fire fighting«. Please ask for this brochure, using the telefax form at the end of the catalogue.